

1/10 EP AWD COMPETITION R/C DRIFT CAR CHASSIS KIT

この度はヨコモ製R/Cカーキットをお買い求め頂き、誠に有り難うございます。このキットは、ワールドチャンピオン メーカーであるヨコモの高性能・競技用R/Cカーです。本説明書に従った正しい組立・安全な走行をして頂ければ、誰でも手軽に楽しむことができます。

Thank you for purchasing this Yokomo product. This high performance competition kit has been proudly manufactured by Yokomo - World Champion R/C car manufacturer. Proper assembly of this product will provide fun, safe enjoyment.

R/C カーを安全に楽しんで頂くための 注意事項

お子様(中学生以下)が 組立・走行する際は、必ず保護者の方が付き添い 安全を確認して下さい。

組立の注意

- 幼児のいる場所では組み立てないで下さい。小さな部品を飲み込む等、非常に危険です。
- 組立の前に必ず内容をお確かめ下さい。万一不良部品、不足部品などがあった場合は、ヨコモ アフターサービス部までお問い合わせ下さい。
- 組立の前に説明書を最後まで読み、全体の流れをつかむと効率的な組立が出来ます。
- 組み立てる際は、様々な工具が必要になります。安全の為に必ず作業内容に合った工具を使用して下さい。又、カッターナイフ等を使用する際は危険を伴いますので、注意して下さい。
- 部品には様々な素材を使用しています。切削加工された金属パーツ等はエッジが鋭く、慎重な組立が必要となります。ケガをしないように注意して下さい。
- プラスチックパーツなどを切断する際は、切断した部品が飛び危険があるので注意して下さい。
- 回転部や駆動部は出来るだけスムーズに動作するように組み立てて下さい。
- 配線やコード類はきれいにまとめて下さい。回転部分や走行路面にコードが接触すると危険です。又、配線は確実に接続されていないとショートなどの恐れや、性能を十分に発揮出来ない場合があります。
- 必要以上の分解、改造をすると、安全性が低下したり走行性能が十分に発揮出来なくなる場合があります。
- 塗装は、周囲に火気の無いことを確認し、換気の良い場所で行って下さい。

走行の注意

- ヨコモ製R/Cカーは競技用の為、時速40kmを超える速いスピードが出るモデルもあります。ルールを守って安全な場所や、R/Cカー用サーキットで走らせて下さい。
- 公道等、周囲の人の迷惑になるような場所では絶対に走らせないで下さい。
- R/Cカーは電波を利用する為、何らかのトラブルで最悪の場合は暴走する事があります。狭い場所や室内は避け、出来るだけ広い、障害物のない場所で走らせて下さい。
- 周囲にR/Cカーを走らせている人がいる場合は、電波が重ならないように、周波数を確認し合って、安全を確かめて下さい。
- R/Cカーは水を嫌います。雨の日や、水たまりのある場所で走らせると、R/Cメカが壊れたり、暴走する危険があります。
- R/Cカーの駆動部分、ギヤやベルト、タイヤなどは高回転で回ります。バッテリーを接続した後は危険ですので、回転部分に手を触れないで下さい。
- 走行後のR/Cカーは各部が高温になる事があります。危険ですので冷却期間をおいてから、メンテナンスなどをして下さい。

走らせる手順

- ①タイヤが空転するように、台の上にR/Cカーを置きます。
- ②スピードコントローラのスイッチがOFFになっている事を確認してから、モーターとバッテリーを接続します。
- ③送信機のアンテナを伸ばし、スイッチをONにします。(送信機の電圧が下がっていると危険です。常に電圧の高い状態で使用して下さい。)
- ④受信機のスイッチをONにします。

走行終了手順

- ①スピードコントローラのスイッチをOFFにします。
- ②バッテリーの接続を外します。
- ③送信機のスイッチをOFFにし、アンテナを縮めます。

バッテリーの取り扱い

(バッテリーに付属の説明書に基づき使用して下さい。)

- バッテリーを充電する際は、周囲に燃えやすい物のない安全な場所で行って下さい。又、高温な場所での充電も避けて下さい。
- バッテリーの充電中は充電状況を常に確認して下さい。充電器の誤動作などで過充電すると、最悪の場合は発火する危険性があります。バッテリー温度が50度を越えたら充電を中止して下さい。
- 走行後のバッテリーは高い温度になります。連続使用するとバッテリーを傷める事になりますので、冷却期間を置いてから充電して下さい。又、走行後のバッテリーはコンディション放電する事によって、性能を持続させる事が出来ます。
- 不要になったバッテリーは一般のゴミと一緒に捨てず、お手数でも電池専用の回収箱に捨てて下さい。

モーターの取り扱い

(モーターに付属の説明書に基づき使用して下さい。)

- 7.2Vのバッテリーでモーターのから回しをするとは危険です。モーター内部を破損し部品が飛び出す事も考えられますので、もしモーターのブレークインをする時は、モーターをしっかり固定し3~5V程度でから回して下さい。
- モーターは定期的なメンテナンスが必要です。劣化するとスピードが出なくなったり、走行時間が短くなります。定期的にクリーニングしたり、ブラシが減ってきたら交換する等のメンテナンスをして下さい。
- モーターの性能に合ったギヤ比を選択して下さい。ギヤ比が最適でないとモーターの性能を十分に発揮出来ないだけでなく、他のR/Cメカを壊す原因にもなります。
- 走行後のモーターは非常に高い温度になります。連続走行するとモーターを傷める事になりますので、冷却期間を置いてから走行してして下さい。

PRECAUTIONS FOR SAFE ENJOYMENT OF YOUR R/C CAR

For children under the age of 13, parental guidance is recommended when running.

ASSEMBLY PRECAUTIONS

- Do not assemble around small children. The parts can be dangerous if accidentally swallowed.
- Check the contents carefully before assembly. Please contact Customer Support if you happen to notice any defective or missing items.
- You will find the assembly process much easier by carefully reading through the manual, and familiarizing yourself with the instructions.
- Many different tools are required during assembly. For safety purposes, please use suitable tools. Exercise extra caution when using a sharp tool such as a hobby knife.
- Many different materials are used for the parts. Use extra care when handling parts with sharp edges, such as machined metal parts.
- When cutting plastic parts, watch for any flying parts.
- Try to assemble any rotating parts or drivetrain parts as smooth as possible.
- Bundle wires neatly away from the ground or any moving drivetrain components. Make sure that all wires are properly connected to prevent shorting.
- Unnecessary modifications may be unsafe and hinder performance.
- Always paint in a well ventilated area away from flames.

PRECAUTIONS BEFORE RUNNING

- Yokomo R/C cars are built for competition use, and some models may exceed speeds of 40km per hour. Practice common sense and run the car in open safe places, or R/C car tracks.
- Do not run the car on public roads with high amounts of traffic, or in areas that may cause an inconvenience to people in that area.
- R/C cars are controlled using a radio frequency. In a worst-case scenario, radio interferences may cause loss of control.
- If others near you are running R/C cars, confirm that they are not running on the same frequency.
- R/C cars do not like water. Avoid running on rainy days, or areas with water puddles. Exposure of the electronics to water may cause loss of control or damage to the electronics.
- The drivetrain of an R/C car consists of many moving parts like gears, belts, shafts, and tires. Avoid touching these areas when the battery is connected.
- Many parts of an R/C car will become hot after running. Allow the parts to sufficiently cool before conducting any maintenance.

BEGINNING A RUN

- ①Place the R/C car on a stand so the wheels are off the ground.
- ②Confirm that the speed controller switch is OFF, and connect the motor and battery.
- ③Extend the transmitter antenna and turn the switch ON. (It is unsafe to use a transmitter with low voltage. Make sure that the transmitter batteries are good before running)
- ④Turn the speed controller switch ON.

FINISHING A RUN

- ①Turn the speed controller switch OFF.
- ②Disconnect the battery.
- ③Turn the transmitter switch OFF, and retract the antenna.

BATTERY USAGE

(Carefully read the instruction included with the batteries.)

- When charging batteries, make sure that the surrounding area is void of anything highly flammable. Also avoid charging in high-temperature locations.
- When charging batteries, frequently monitor the charging it catch on fire. If the battery reaches 50 degrees Celcius or more, stop charging.
- Batteries will become hot after running. Continuous use of the battery pack may result in damage to the cells. Allow the battery too cool down before re-charging. Using a battery conditioner after running may prolong the life and performance of the battery.
- Please do not discard old battery packs in the trash. Although inconvenient, please locate a battery disposal center.

MOTOR USAGE

(Carefully read the instruction included with the motor.)

- Connecting a 7.2V battery directly to the motor can be very dangerous. This may cause the internal parts of the motor to break apart, causing some parts to fly out of the motor. To break-in the motor, safely secure the motor and run the motor at about 3-5V.
- Motors require periodic maintenance. Slower speeds and decreased run times may indicate a worn-out motor. Periodically clean the motor and change the brushes when needed.
- Choose a gear ratio that matches the power characteristics of the motor. Using a gear ratio unsuited to the characteristics of the motor will not only prevent the motor from performing at its optimum, but may even cause damage to the other electronics.
- Motors will generally become very hot after running. Continuous running will reduce the life of the motor. Allow the motor to sufficiently cool between each run.

【組み立てに必要な物】

ACCESSORIES AND TOOLS NEEDED FOR [DRIFT PACKAGE YD-4] ASSEMBLY

■ 走行の為に別にお買い求め頂く物 ■

ADDITIONAL ITEMS REQUIRED FOR USE (NOT INCLUDED IN KIT)

- 2チャンネルプロポ (1サーボ 1アンプ仕様)
**TWO CHANNEL R/C SURFACE RADIO SYSTEM
AND ELECTRONIC SPEED CONTROL**
- 走行用パックバッテリー
PACK BATTERY
- 走行用バッテリー充電器
BATTERY CHARGER
- 走行用モーター
MOTOR
- タイヤ&ホイール(タイヤ付キットは不要)
TIRES & WHEEL
- 走行用ボディー(ボディー付キットは不要)
BODY
- ボディー塗装用カラー
BODY SPRAY PAINT

■ 別途用意する工具 ■

ASSEMBLING TOOLS REQUIRED (NOT INCLUDED IN KIT)

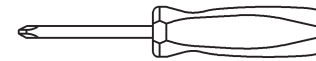

ドライバー (大,小)
SCREW DRIVER (SMALL & LARGE)

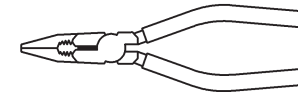

ラジオペンチ
NEEDLE NOSE PLIERS

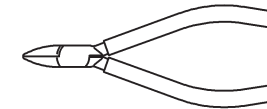

ニッパー
SIDE CUTTER

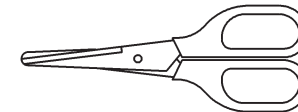

ハサミ
SCISSORS



カッター
HOBBY KNIFE

■ キットに入っている工具 ■

TOOLS (INCLUDED)



六角レンチ
ALLEN WRENCH
(1.5mm & 2.0mm)



ターンバックルレンチ
TURNBUCLE WRENCH

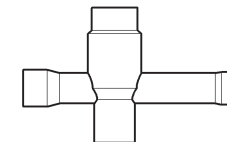





十字レンチ
NUT WRENCH

**[DRIFT PACKAGE YD-4]の性能を十分に発揮させる為に
イラストを良く参照し説明の順番に従って確実に組み上げて下さい。**

**For assembly, follow the figures and the instructions closely
so that your [DRIFT PACKAGE YD-4] will perform at its best!!**

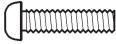
[Bag-1 Contents]

-  --x4 **M3x10 flat head screw**
-  --x6 **M3x12 flat head screw**
-  --x4 **M3x18 flat head screw**
(For battery mount spacer)
-  --x2 **M3x12 button head screw**
-  --x2 **Washer (black)**
-  --x2 **King pin collar**

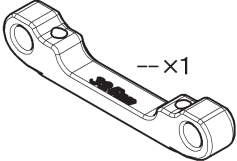
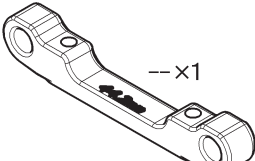
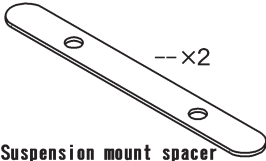
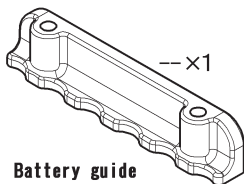
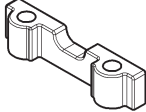
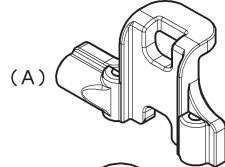
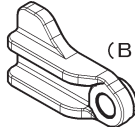
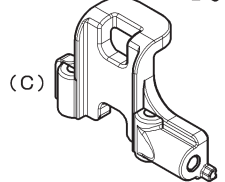
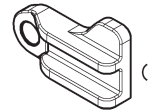
-  --x1
-  --x1
-  --x2
-  --x1
-  --x2
-  (A)
-  (B)
-  (C)
-  (D)
- x1 Battery mount**

[Bag-16 Contents]

-  --x1 **Allen key (1.5mm & 2.0mm)**

Also included: Nut wrench, Turnbuckle wrench

All of the 3mm set screws included in this kit are allen head set screws. To tighten, please use a 2.0mm allen wrench or the 2.0mm allen key included in this kit.

If you happen to find the 2.0mm allen key difficult to use, an optional 2.0mm allen wrench from Yokomo is available. Part no. YT-20W

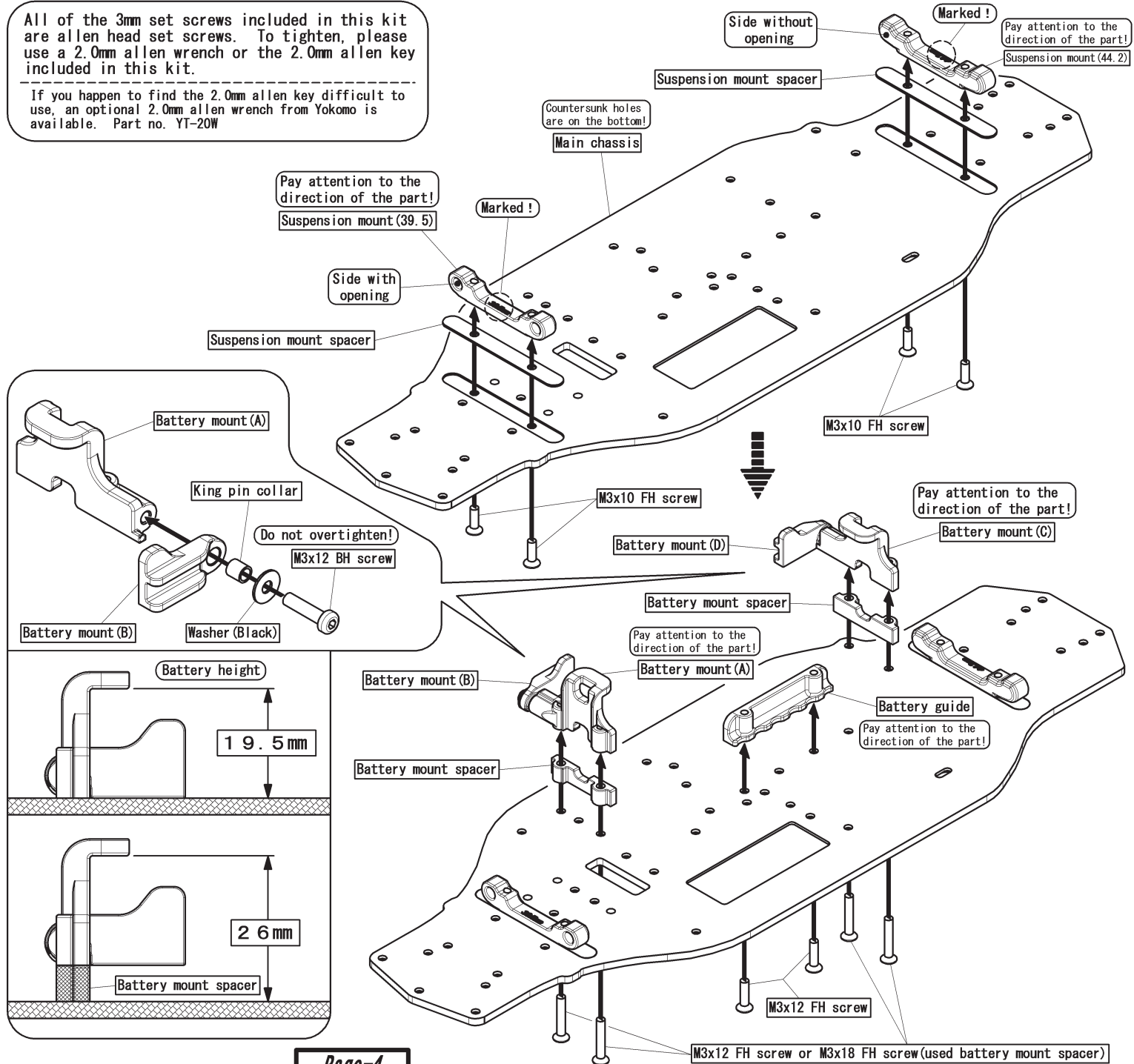

Square edge standard size battery pack

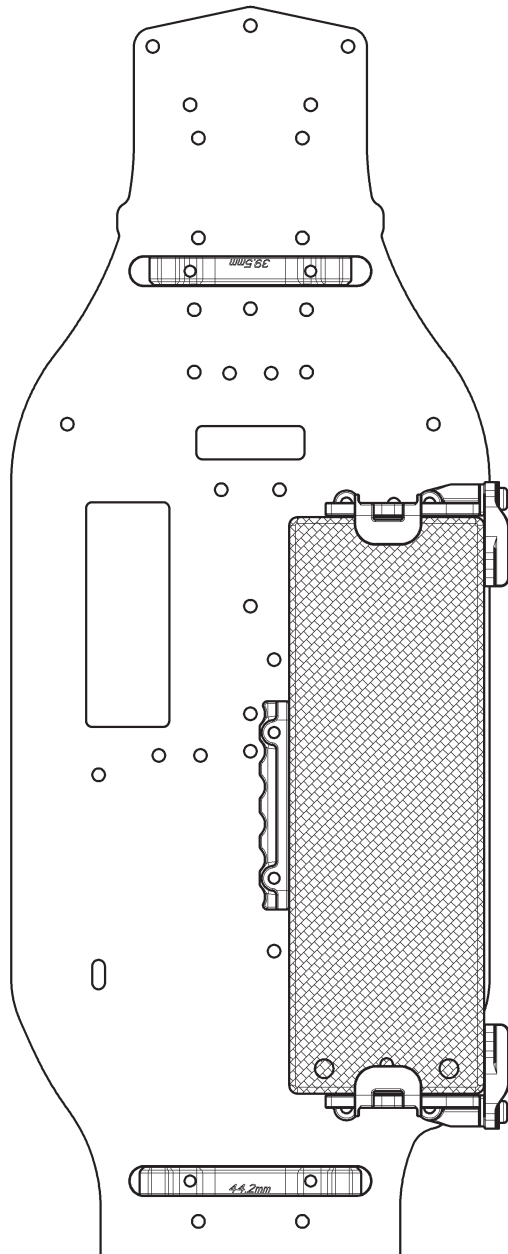



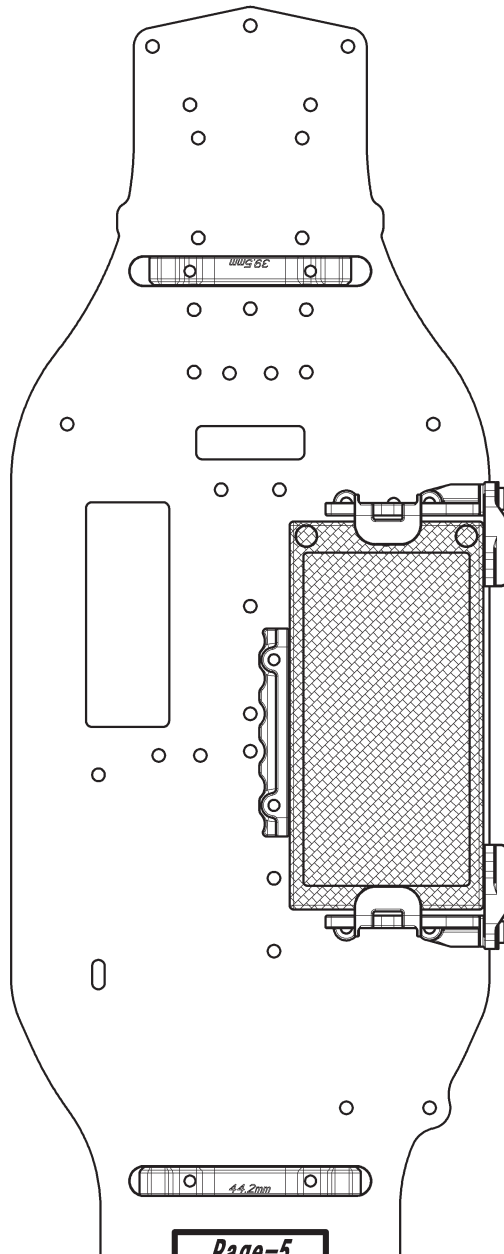

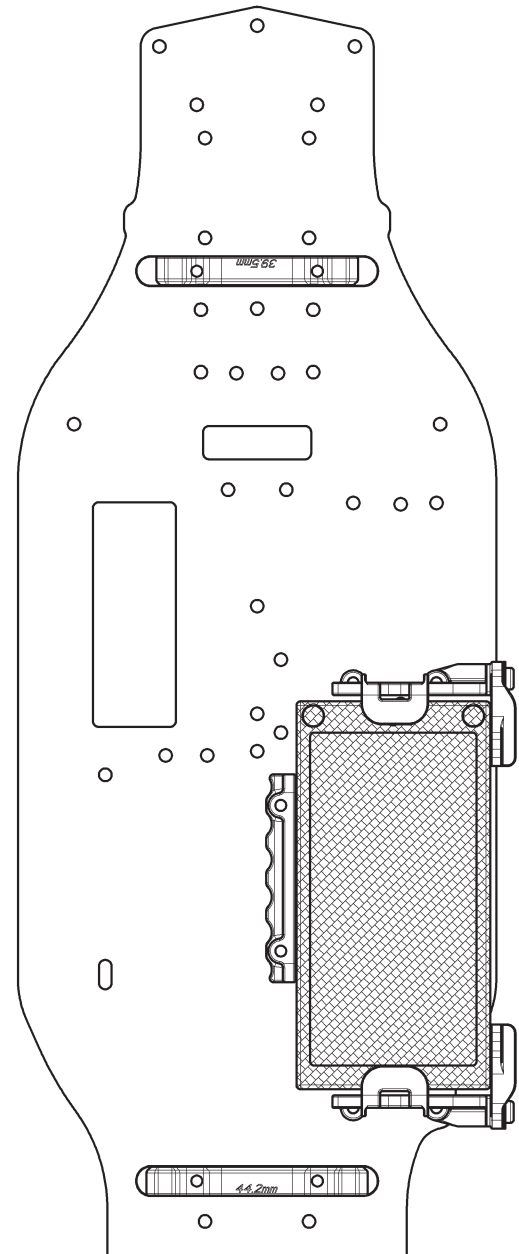

Square edge short size battery pack (Front side)







Square edge short size battery pack (Rear side)

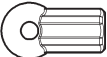

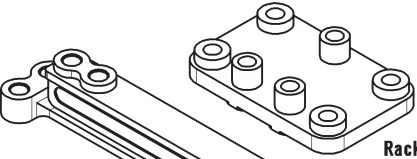

[Bag-2 Contents]

-  --x1
-  --x7
-  --x1
-  --x4
-  --x5
-  --x2
-  --x4

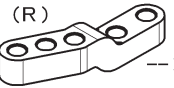
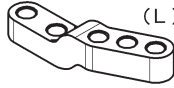
※There are 3 different ball end lengths (S), (M), (L).

-  --x2
-  --x2
-  --x1
-  --x1
-  --x1
-  --x1
-  --x1

-  --x2
-  --x8

Remaining parts from [Bag-1 Contents]

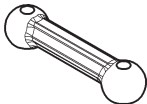
-  --x1
-  --x1

One side of the turnbuckle is reverse threaded.

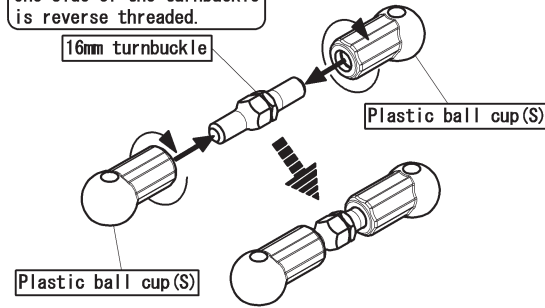

Assemble 2 rods

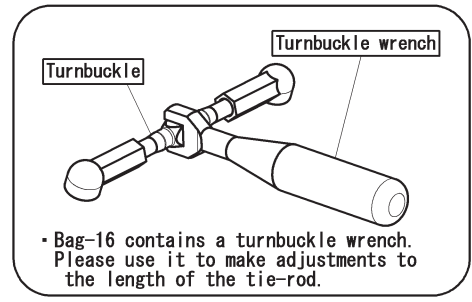
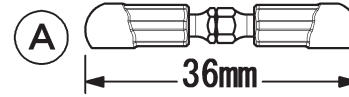



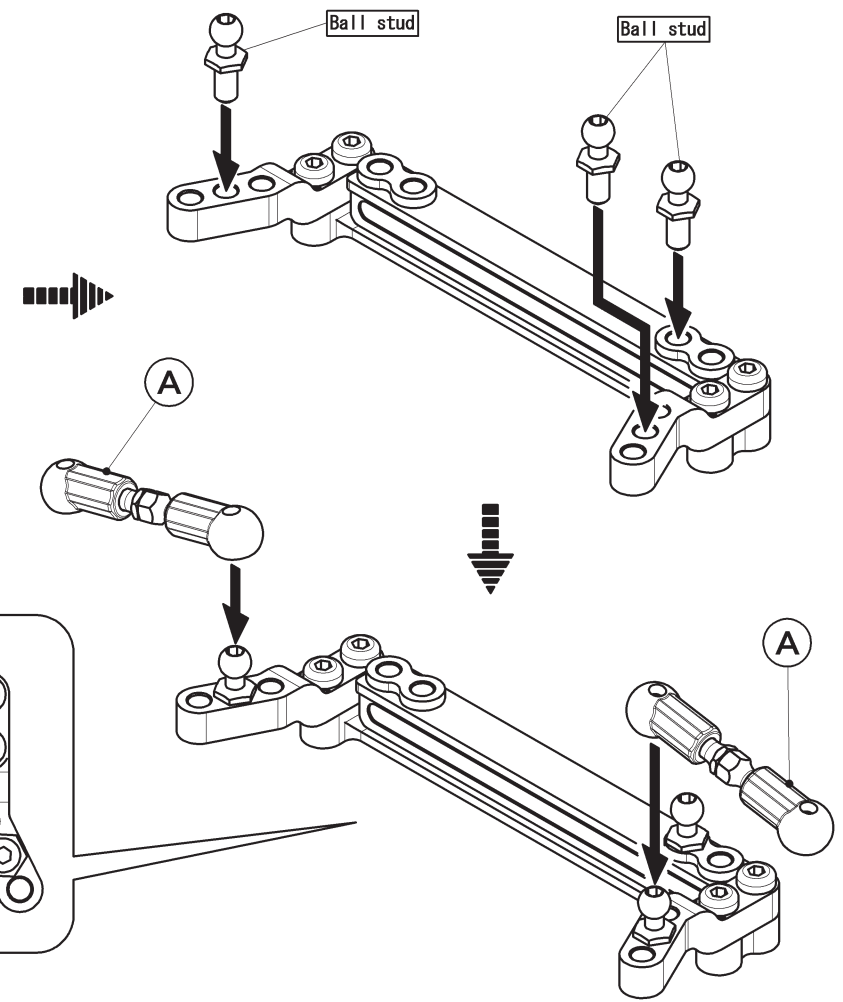
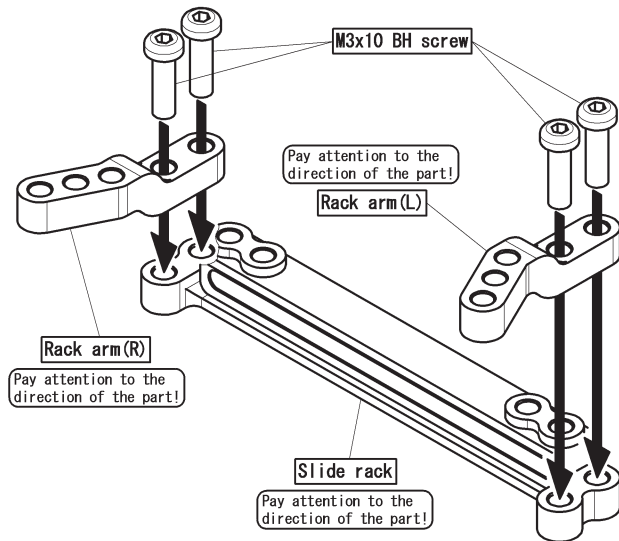

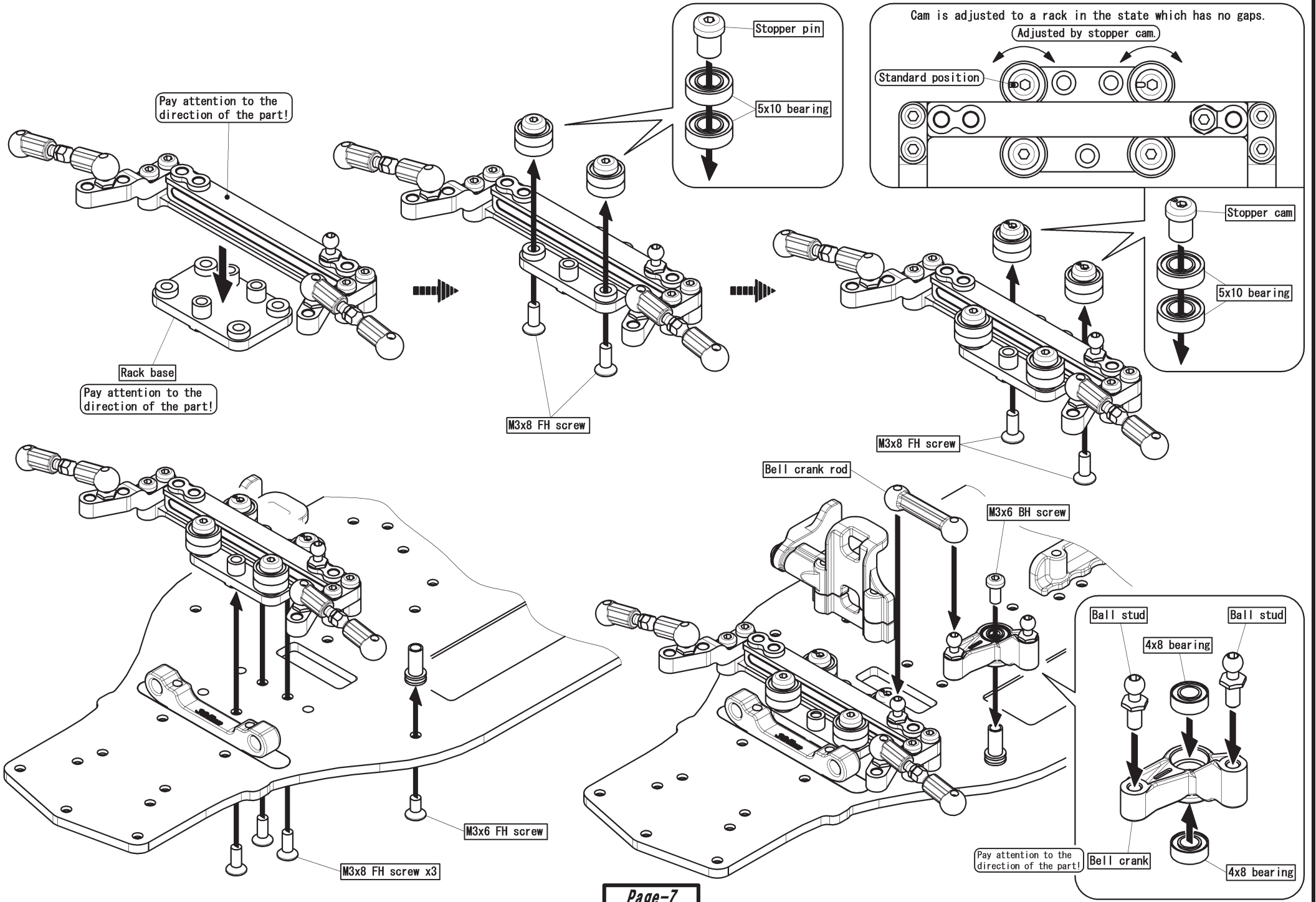

Assemble the tie-rod by attaching a plastic ball cup to both ends of the turnbuckle.



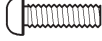
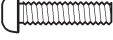

[Bag-3 Contents]

-  --x2 M3x8 flat head screw
-  --x1 M3x10 flat head screw
-  --x2 M3x6 button head screw
-  --x3 M3x10 button head screw
-  --x1 M3x12 button head screw
-  --x1 M3x3 set screw
-  --x4 Washer (black)
-  --x1 24 T Pinion gear

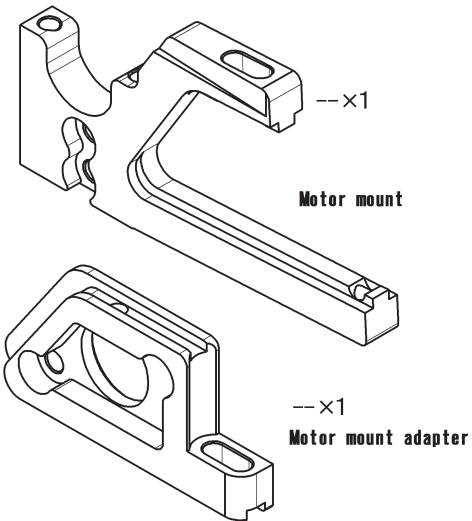

Remaining parts from [Bag-1 Contents]

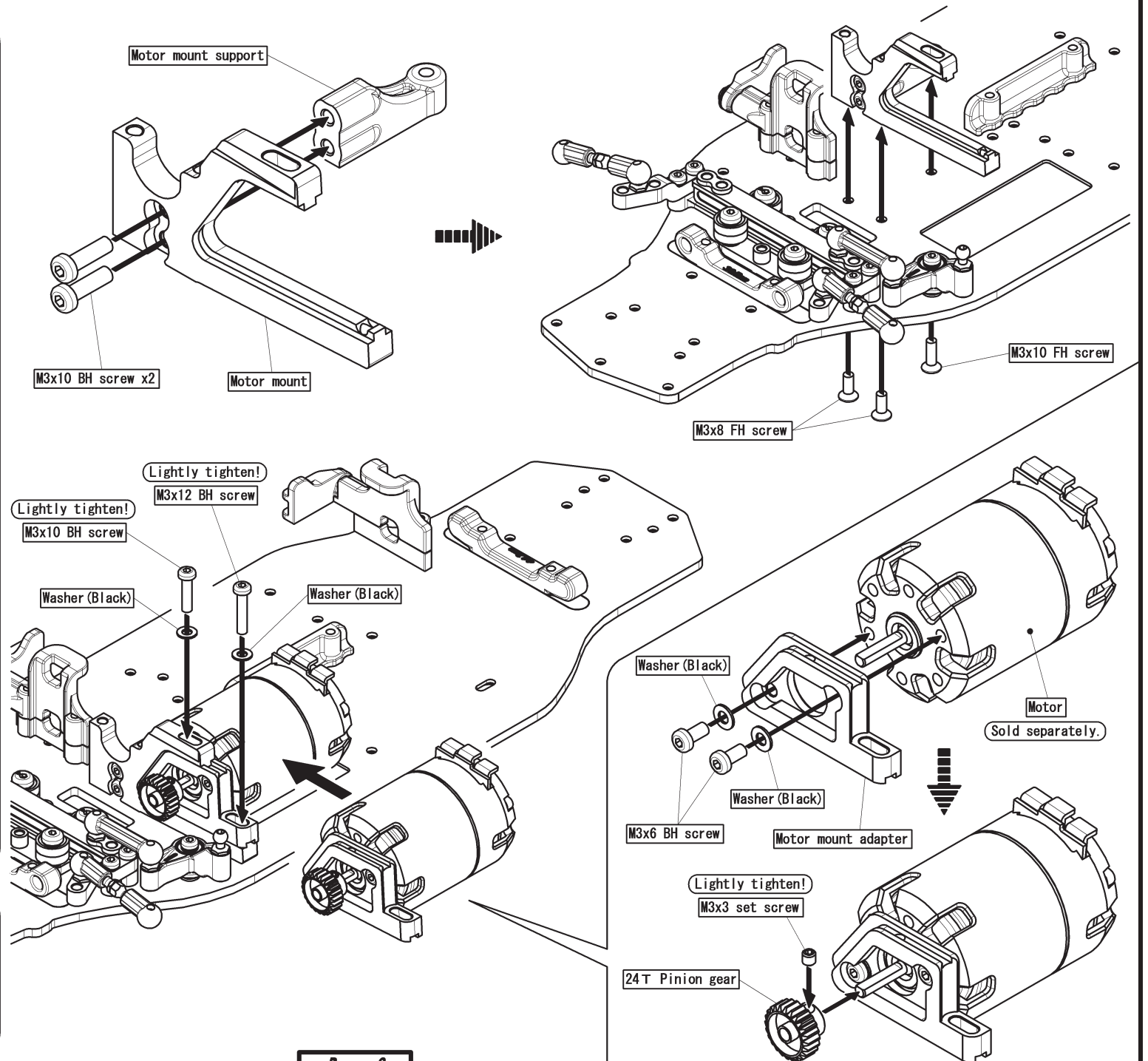
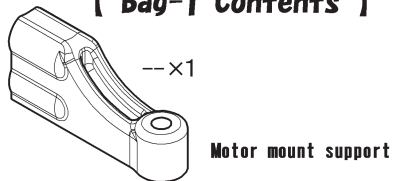

[Bag-4 Contents]
[FRONT ONE-WAY PARTS]

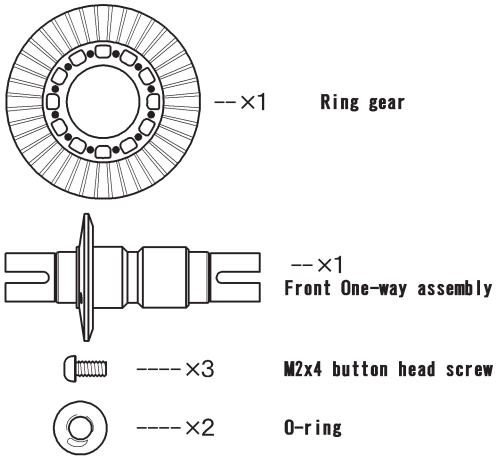

[SOLID AXLE PARTS]

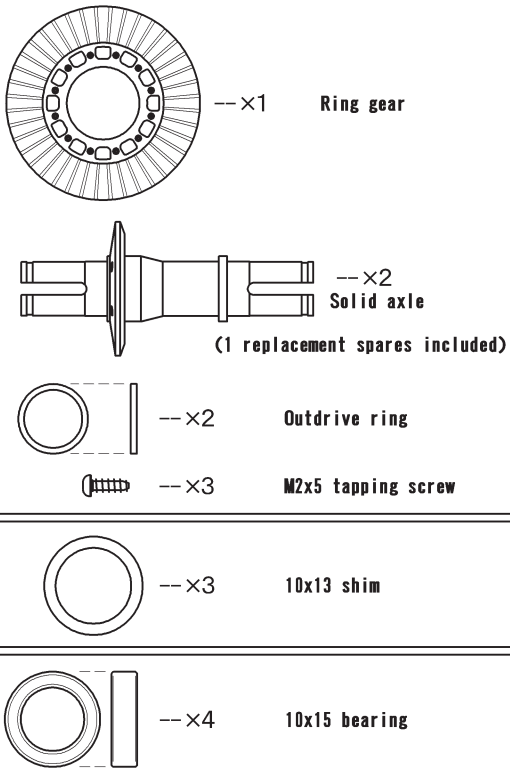

Front One-way Assembly

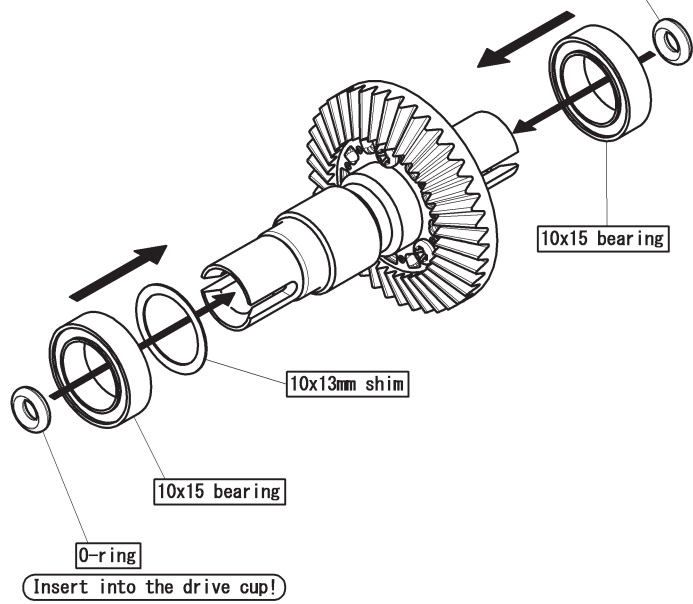
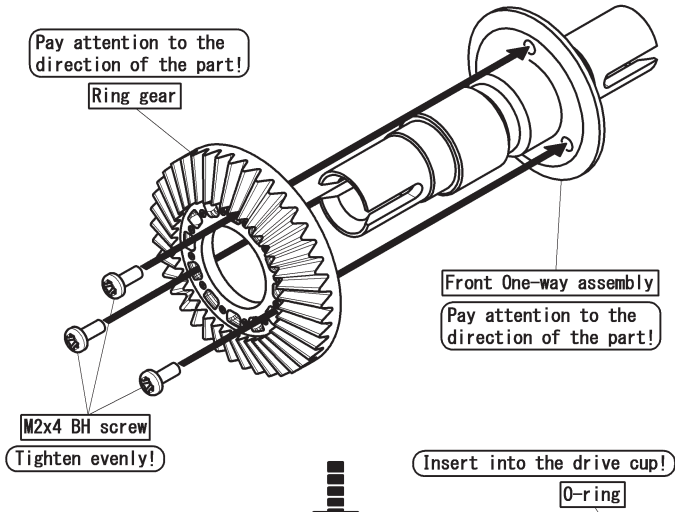

Solid Axle Assembly

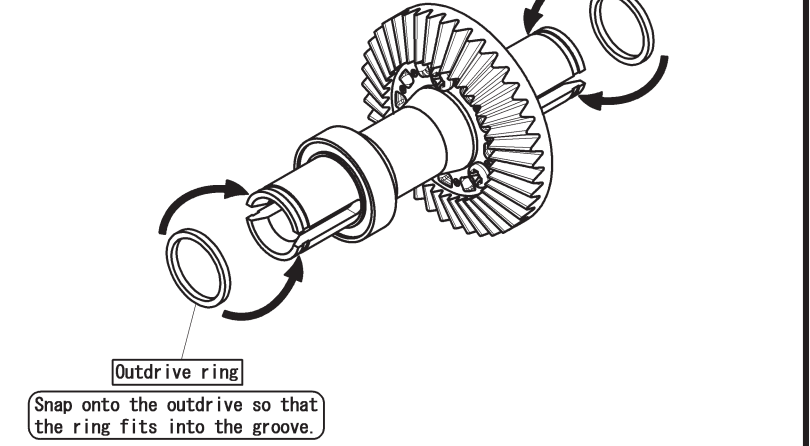
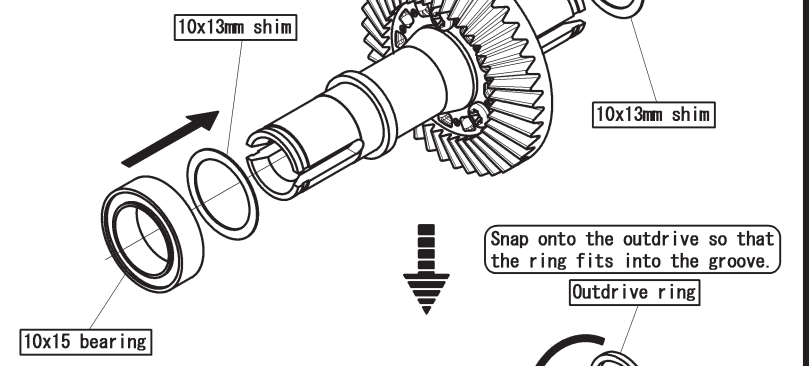
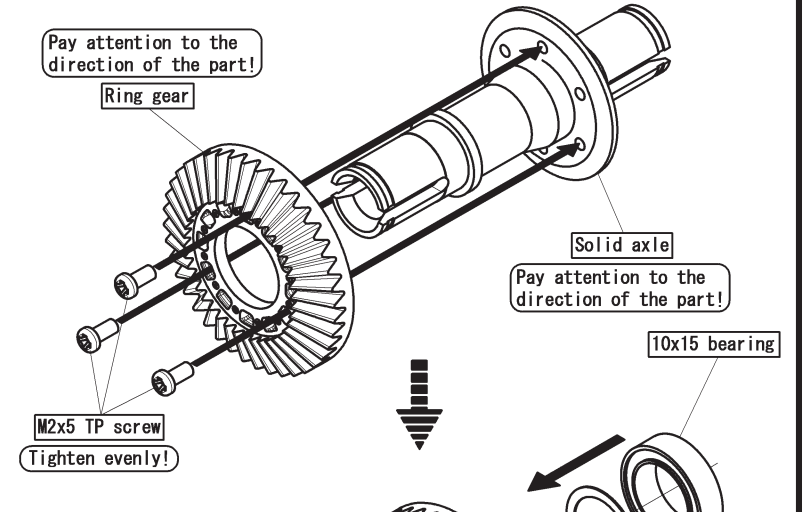

[Bag-5 Contents]

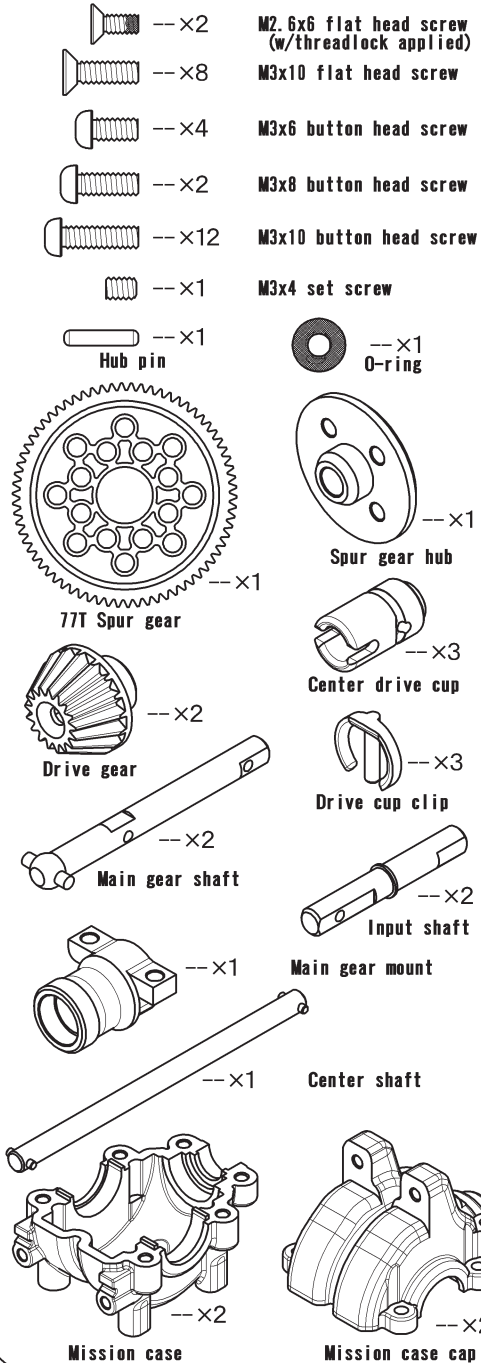

Important!— Make sure the 2.6x6mm flat head screw is securely tightened.

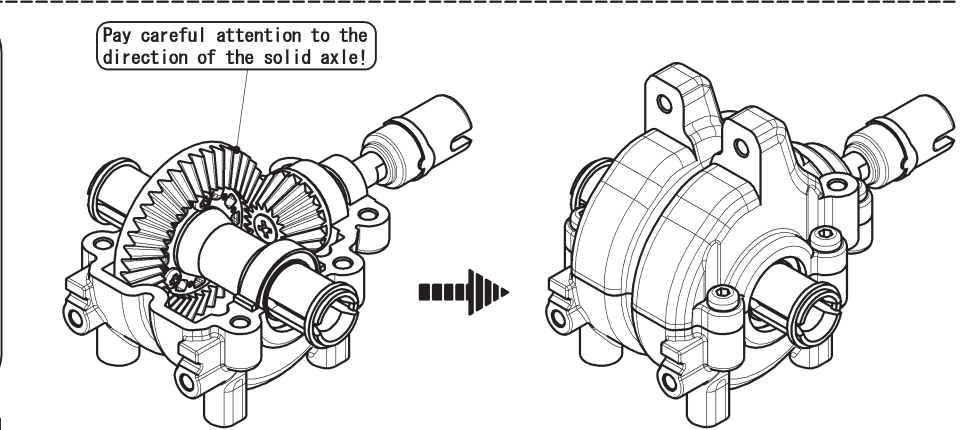
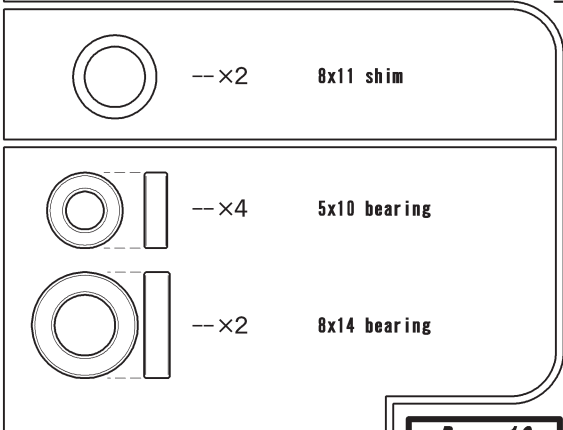
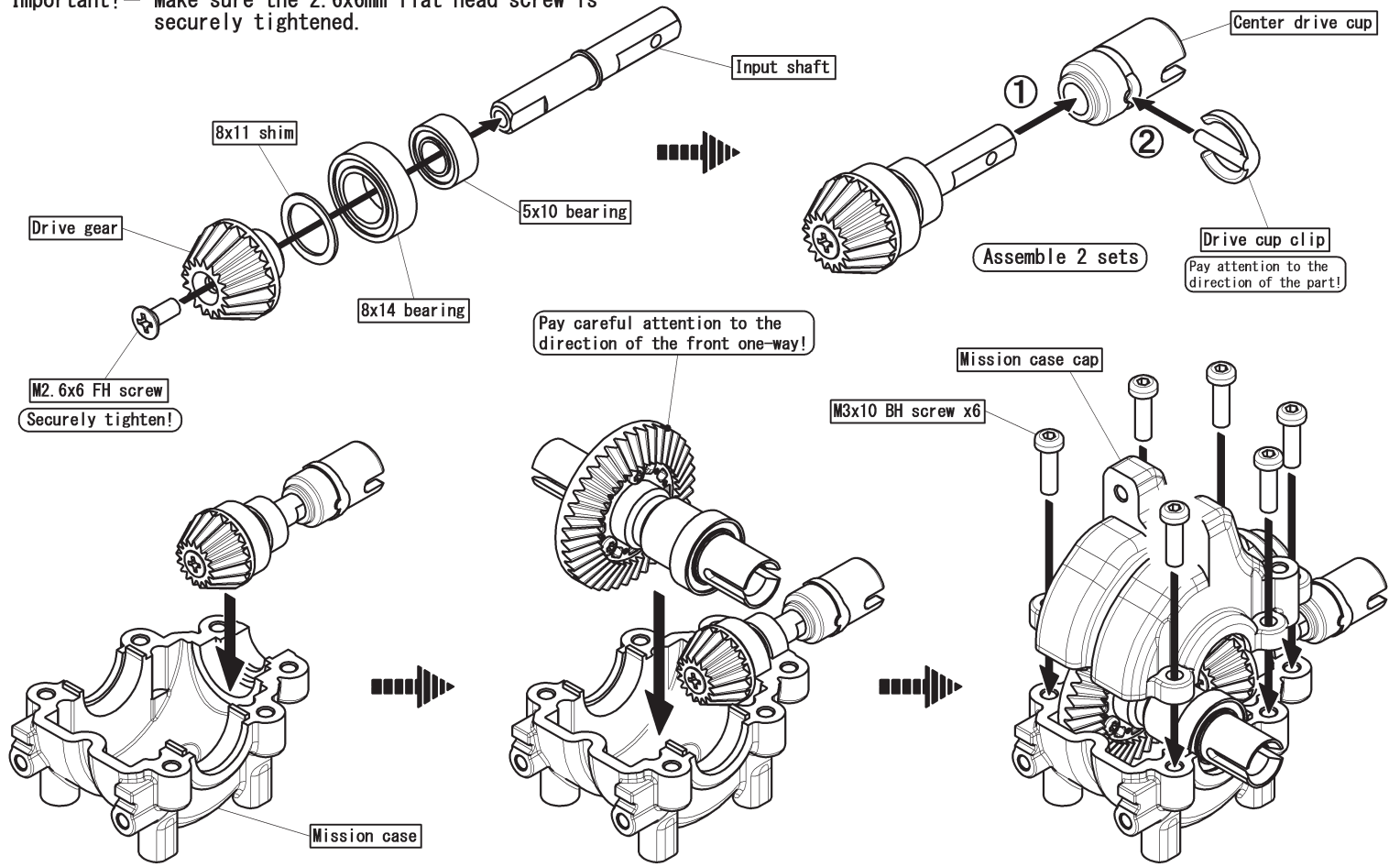

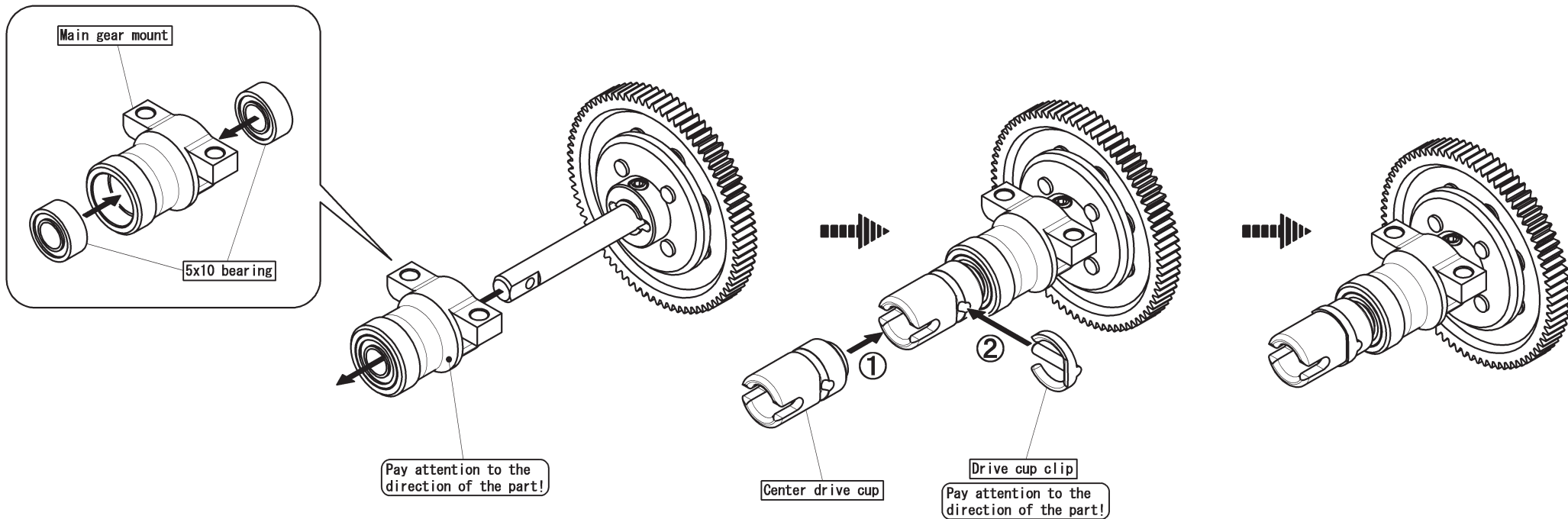
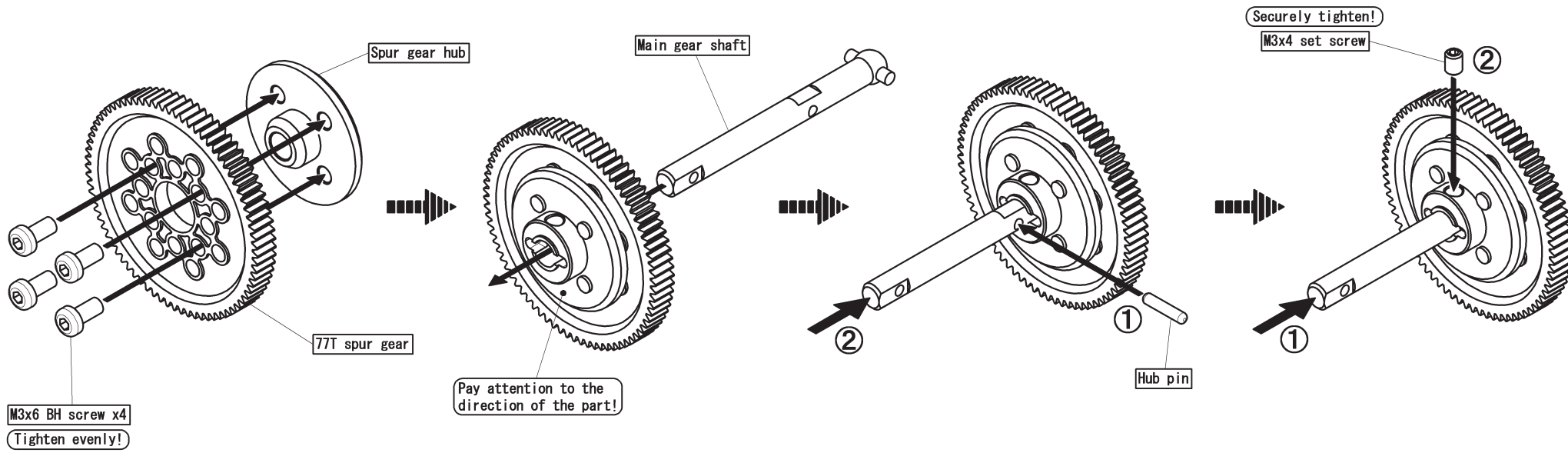

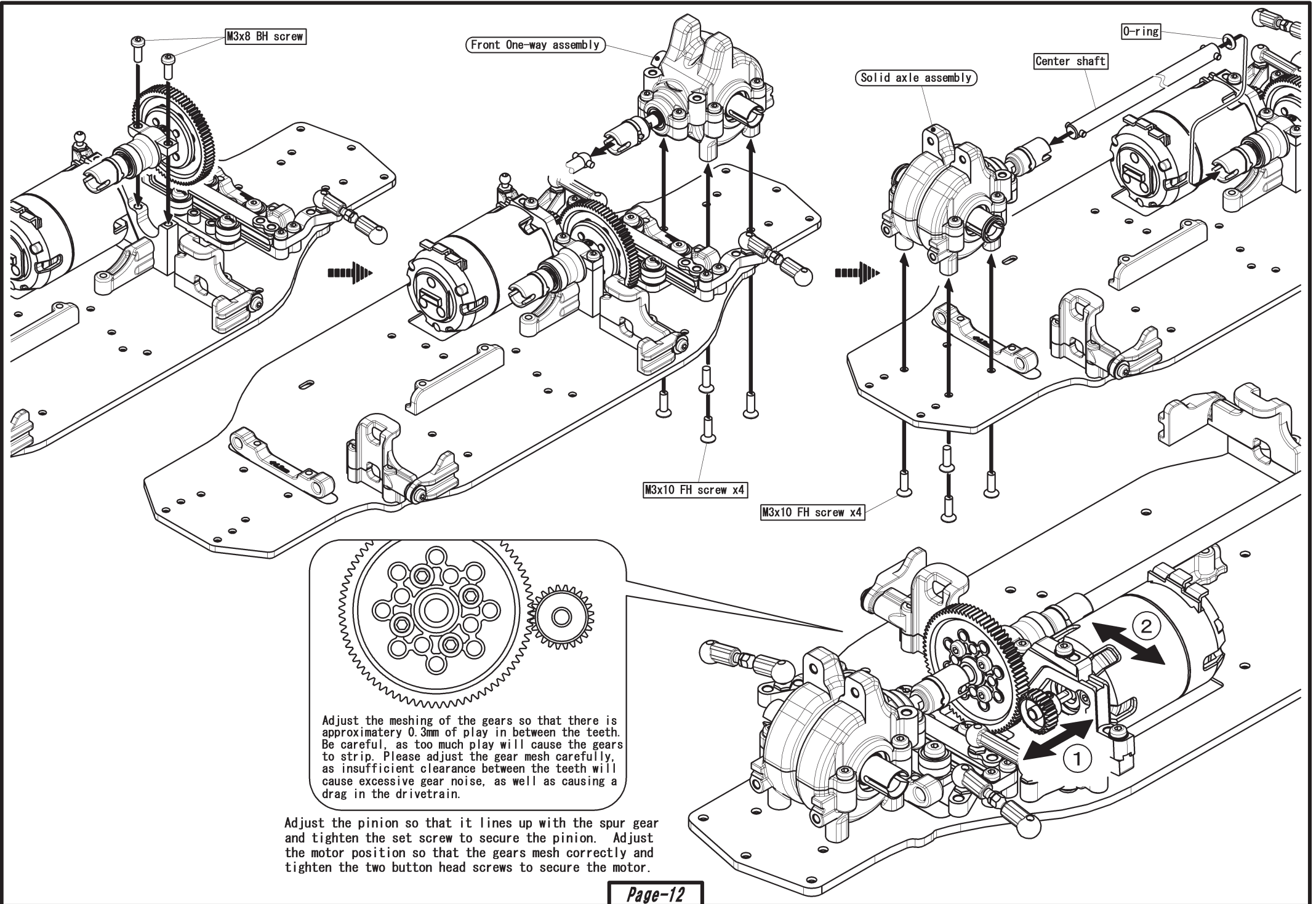

M3x8 BH screw

Front One-way assembly

Solid axle assembly

Center shaft

O-ring

M3x10 FH screw x4

M3x10 FH screw x4

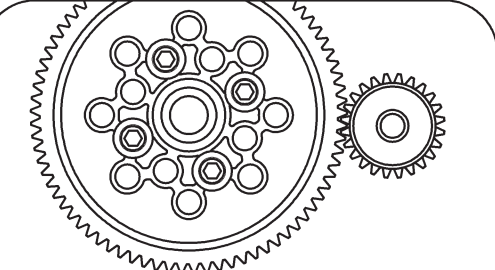

Adjust the meshing of the gears so that there is approximately 0.3mm of play in between the teeth. Be careful, as too much play will cause the gears to strip. Please adjust the gear mesh carefully, as insufficient clearance between the teeth will cause excessive gear noise, as well as causing a drag in the drivetrain.

Adjust the pinion so that it lines up with the spur gear and tighten the set screw to secure the pinion. Adjust the motor position so that the gears mesh correctly and tighten the two button head screws to secure the motor.

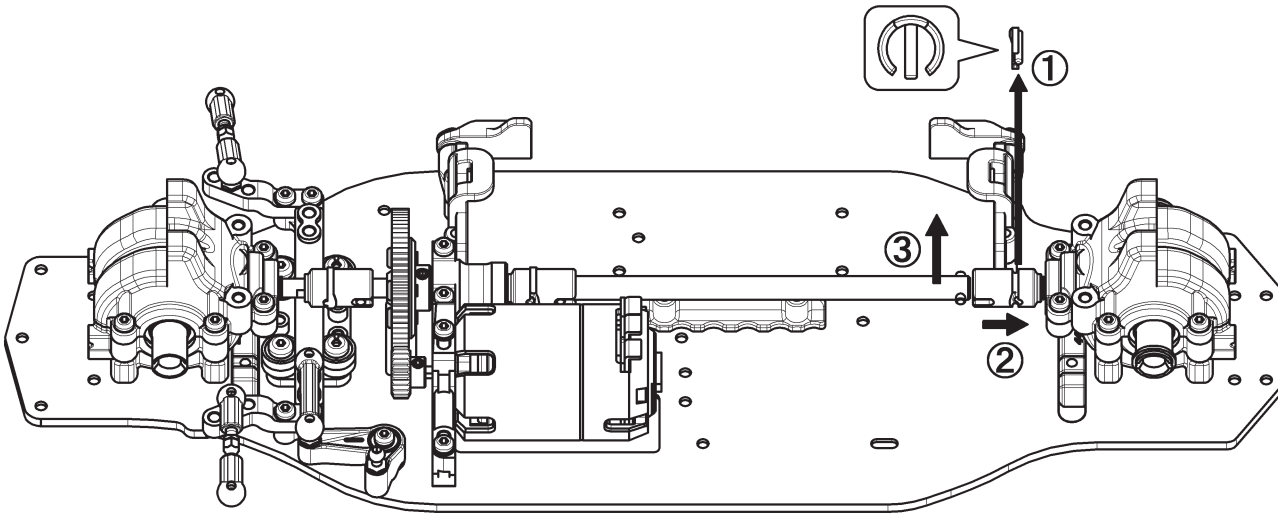

Center Shaft Removal

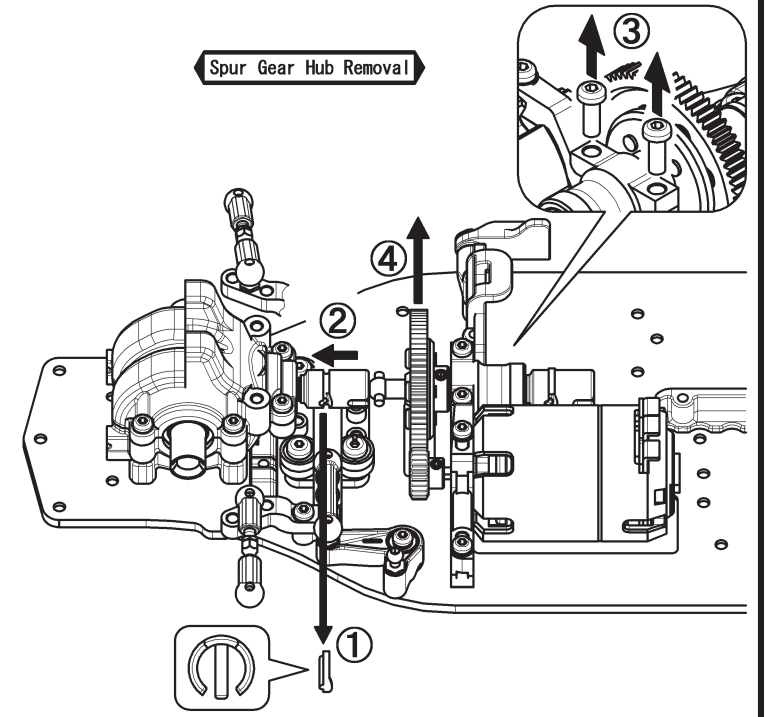

Spur Gear Hub Removal



[Bag-6 Contents]

-  --x1 M3x8 button head screw
-  --x4 M3x10 button head screw

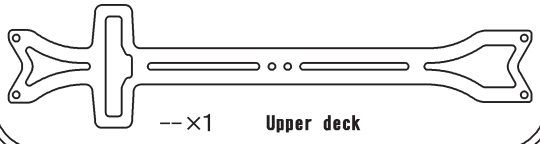

Remaining parts from [Bag-1 Contents]

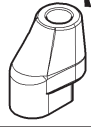
-  --x1 Antenna mount

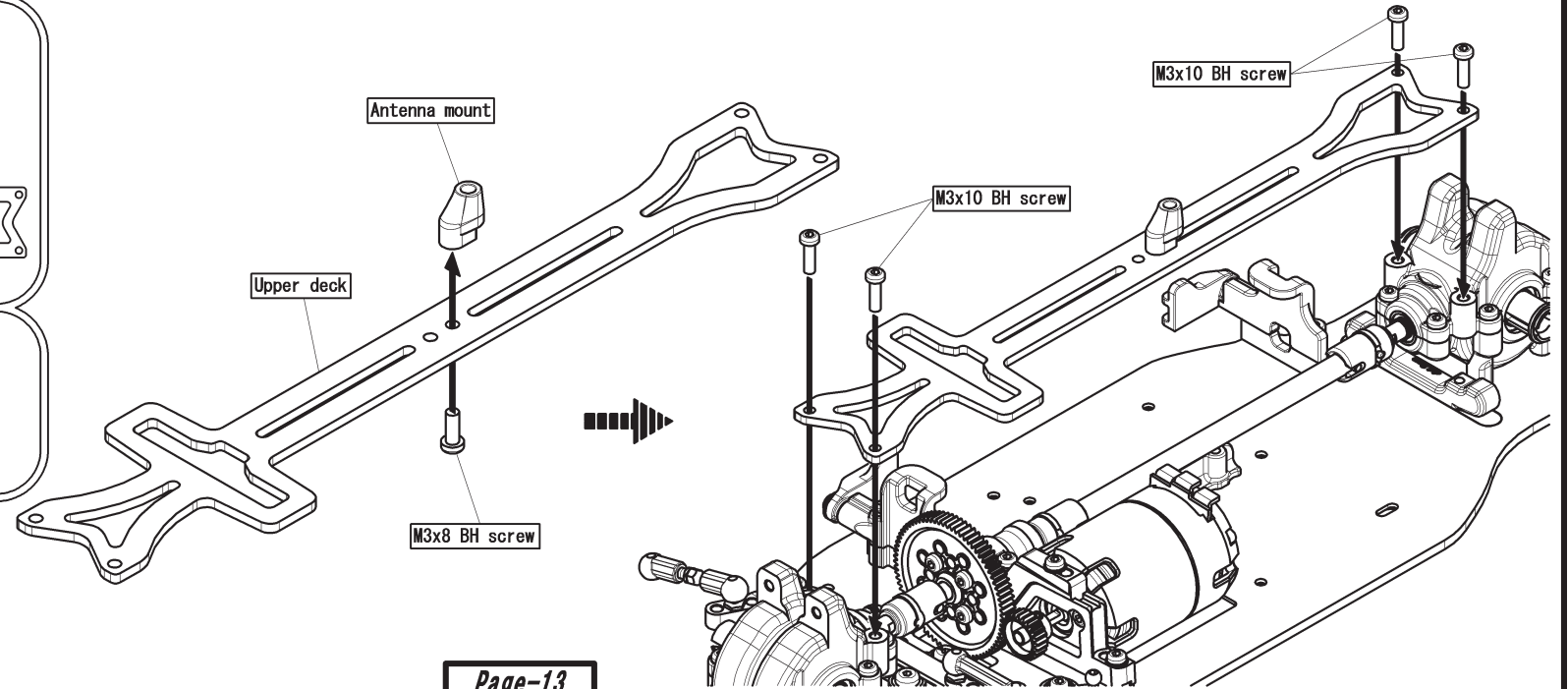

[Bag-7 Contents]

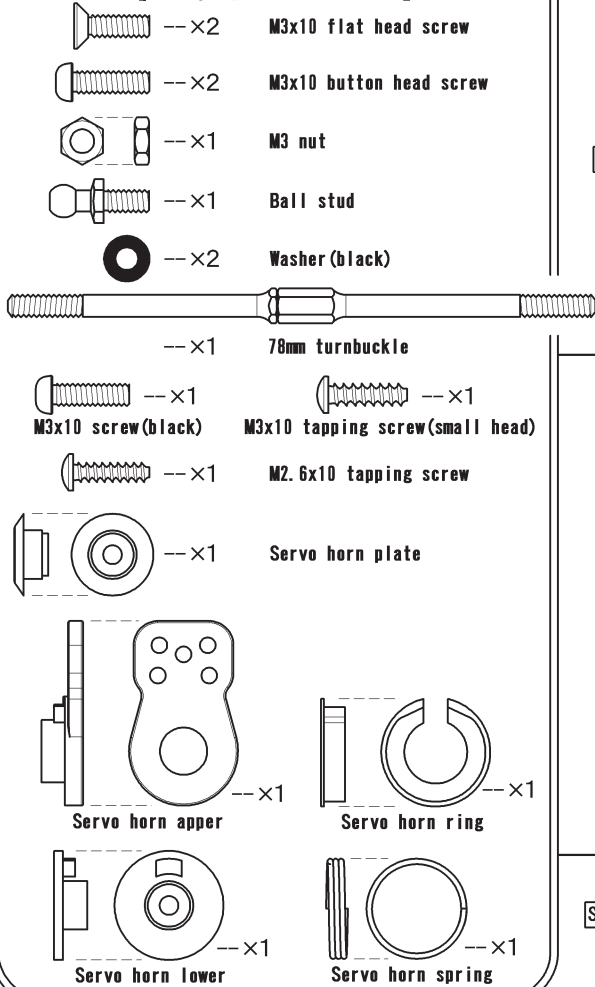

Remaining parts from [Bag-1 Contents]

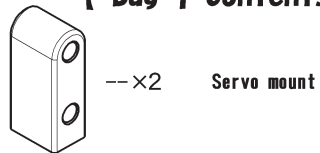

Remaining parts from [Bag-2 Contents]

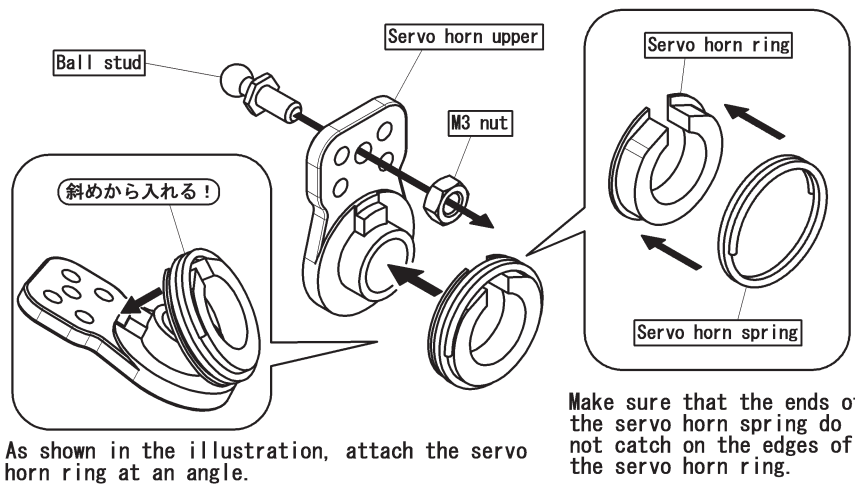
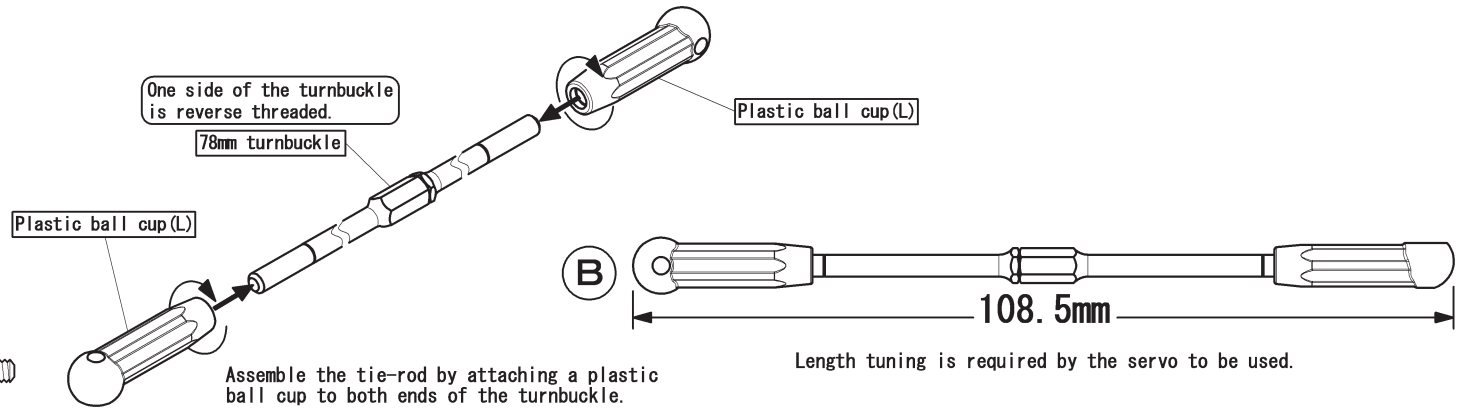
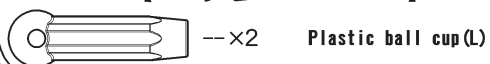

Mark	Manufacturer
Y	Yokomo S005
Y F	Yokomo S003, Futaba
J K S	Yokomo S008, JR, KO, Sanwa

The included servo horn lower are marked with a letter designating servo compatibility. Select the servo horn matching the servo being used.

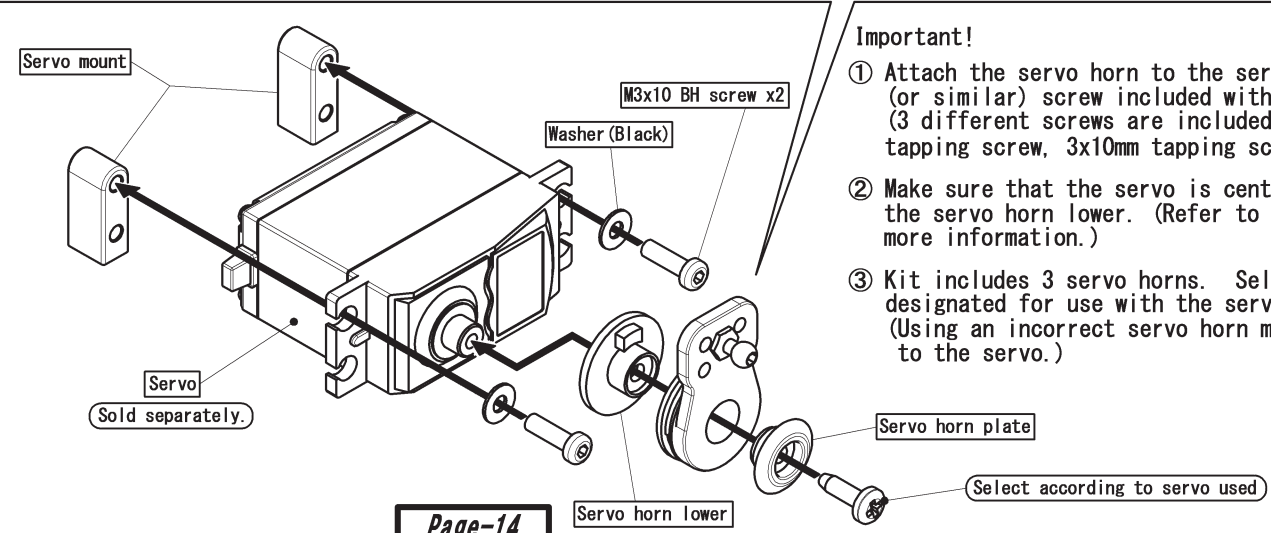
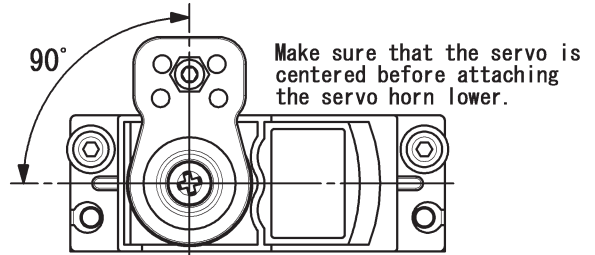

Important!



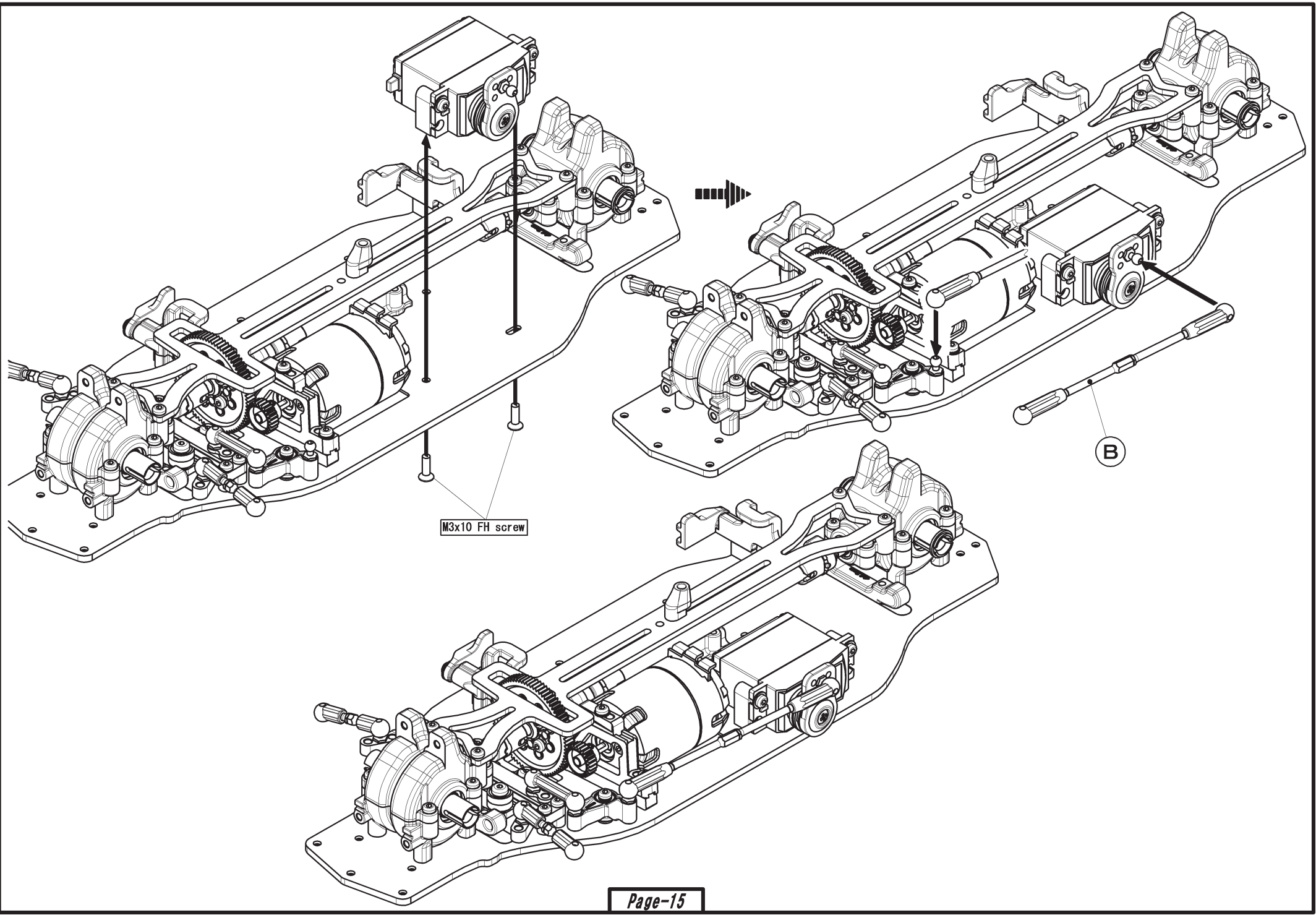



- ① Attach the servo horn to the servo using the same (or similar) screw included with the servo unit. (3 different screws are included in the kit: 2.6x10mm tapping screw, 3x10mm tapping screw, 3x10mm screw)
- ② Make sure that the servo is centered before attaching the servo horn lower. (Refer to your radio manual for more information.)
- ③ Kit includes 3 servo horns. Select the servo horn designated for use with the servo being used. (Using an incorrect servo horn may result in damage to the servo.)

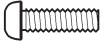

M3x10 FH screw

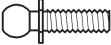
B

[Bag-8 Contents]

-  --x4 M3x10 flat head screw
-  --x4 M3x10 button head screw
-  --x4 M3 nylon locknut
-  --x4 King pin (ball type)
-  --x4 Shock cap ball
-  --x2 30mm turnbuckle
-  --x2 39mm turnbuckle

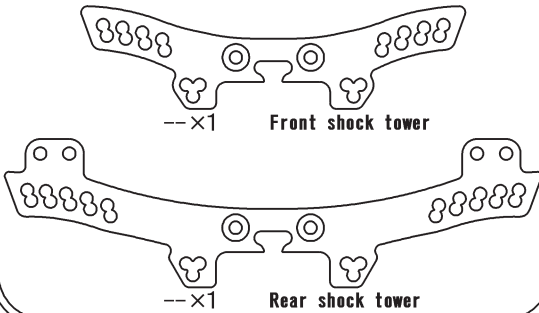

Remaining parts from [Bag-2 Contents]

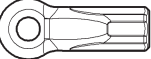
-  --x4 Plastic ball cup (M)
-  --x4 Plastic open ball cap

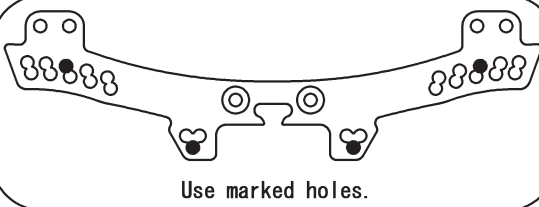
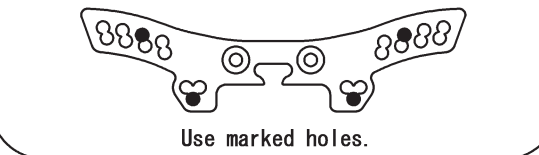

One side of the turnbuckle is reverse threaded.

30mm & 39mm turnbuckle

Plastic open ball cap

Plastic ball cup (M)

Assemble the tie-rod by attaching a plastic ball cup to both ends of the turnbuckle.

30mm turnbuckle

C

54.5mm

Assemble 2 rods

39mm turnbuckle

D

63.5mm

Assemble 2 rods

Installing on front shock tower

Pay attention to the direction of the part!

Front shock tower

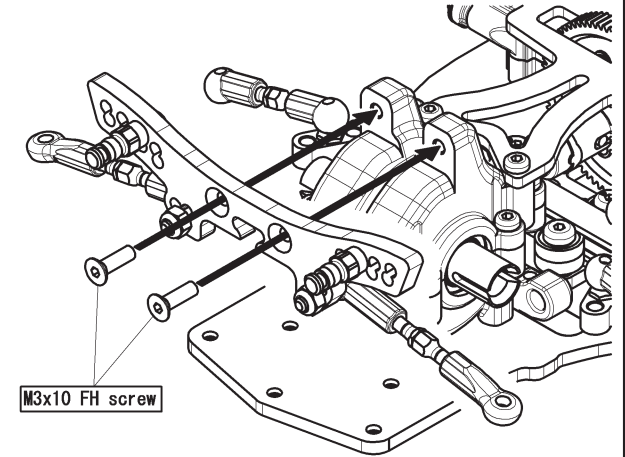
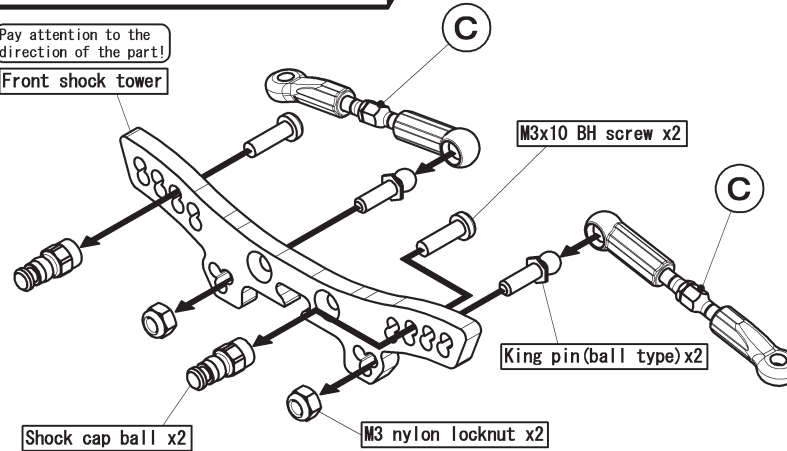

Installing on rear shock tower

Rear shock tower

Pay attention to the direction of the part!

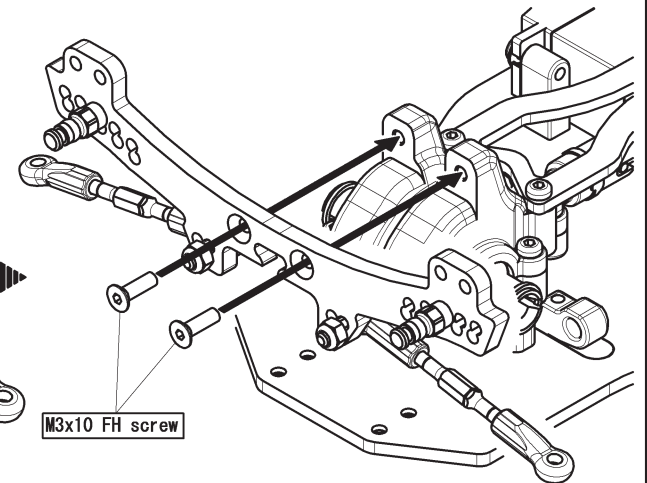
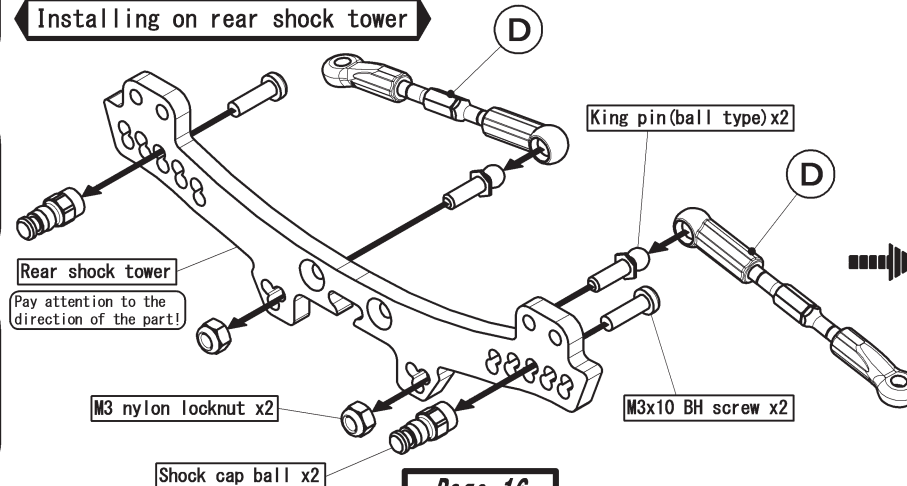

[Bag-9 Contents]

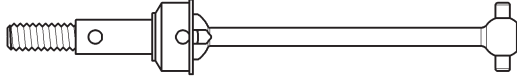

--x4 Assembled universal driveshaft
Also included: Black grease x1

[Bag-10 Contents]

- x4 Ball stud
- x2 King pin(ball type)
- x2 King pin collar
- x2 King pin

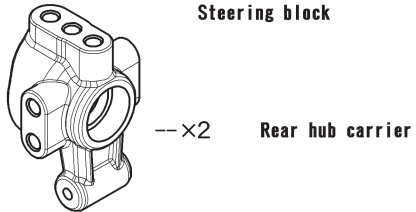
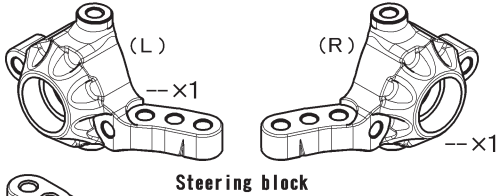
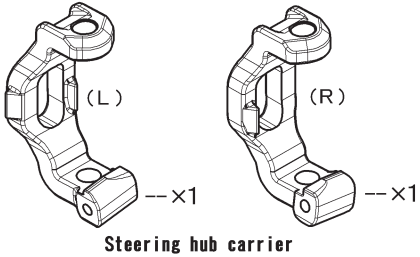

- x4 5x10 bearing
- x4 10x15 bearing

Front Hub Carrier Assembly

Assemble 2 sets
(The steering hub carriers are different left and right.)

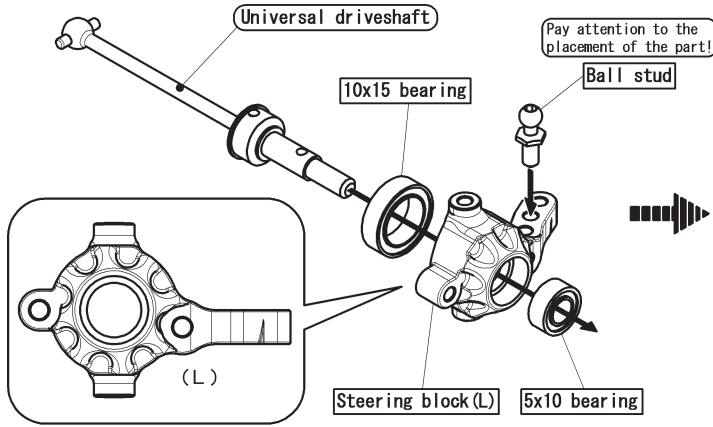

Important!

- ① The left and right steering hub carriers are different.
- ② Slowly tighten the upper king pin. Overtightening the king pin may cause the king pin collar to be squished, preventing the steering block from moving freely.

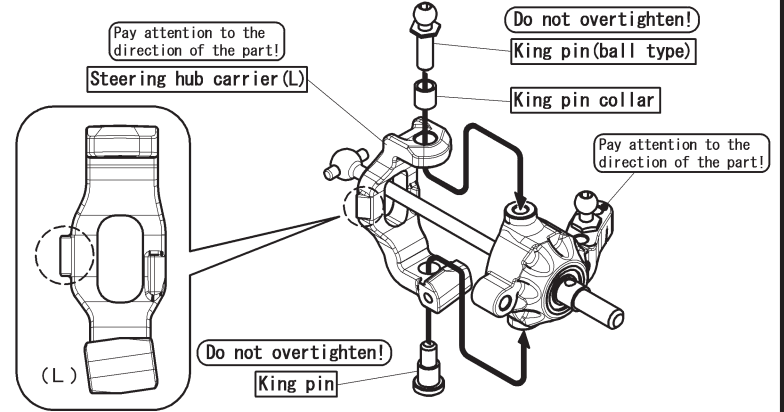

Rear Hub Carrier Assembly

Assemble 2 sets

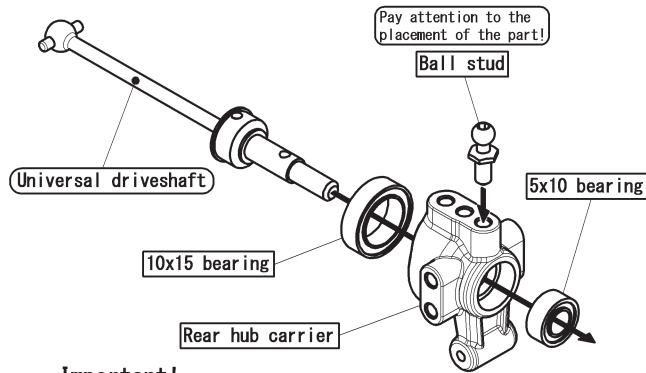

[Assemble each side in the same manner.]

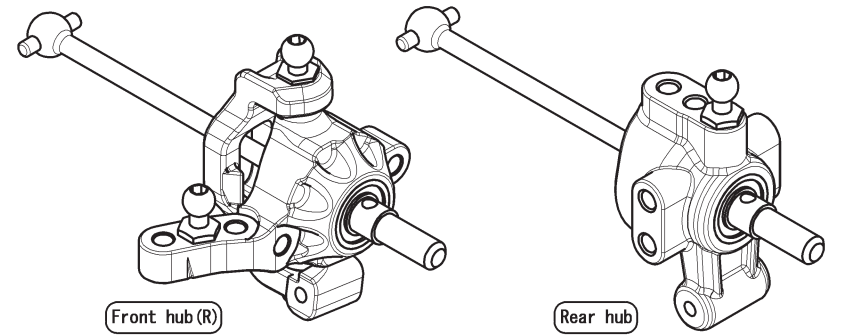

Important!

- ③ When using all except for directions of an illustration, ZC-206SH is needed.

Universal Driveshaft Assembly

Perform when maintenance is required.

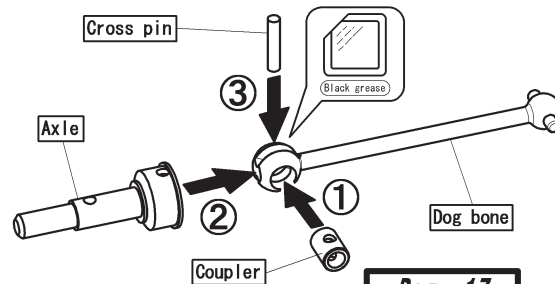





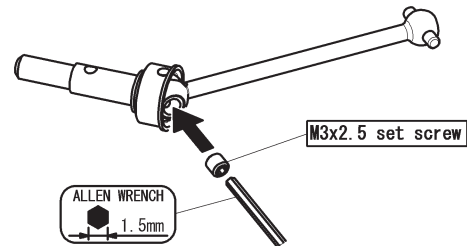





Important!

- ④ View the illustration on the left when assembling the universal drive shafts. Make sure to apply black grease. Follow the directions in reverse for disassembly.

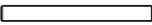
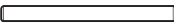

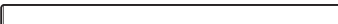
[Bag-11 Contents]

-  --x4 M3x8 flat head screw
-  --x4 M2x4 tapping screw
-  --x4 M4x8 set screw
-  --x2 Ball stud
-  --x2 Shock end ball
-  --x8 Inner suspension arm pin ball
-  --x2 Outer suspension arm pin (S)
-  --x2 Outer suspension arm pin (L)
-  --x2 Inner suspension arm pin (S)
-  --x2 Inner suspension arm pin (L)
-  --x4 Collar
(Included with the suspension arms.)

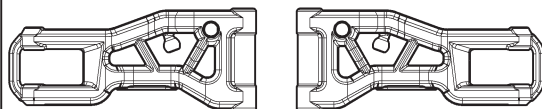

(R) --x1 (L) --x1



Front lower suspension arm

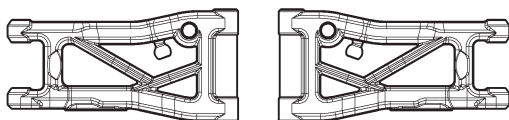

(L) --x1 (R) --x1



Rear lower suspension arm

Remaining parts from [Bag-1 Contents]

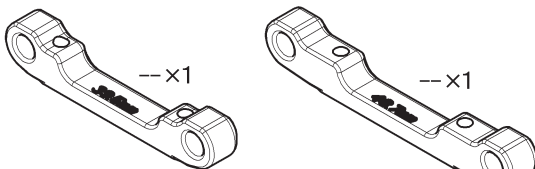

Suspension mount (39.5) Suspension mount (48.7)

Front Assembly

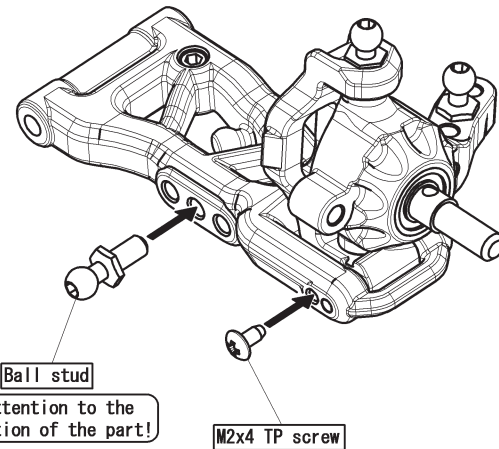
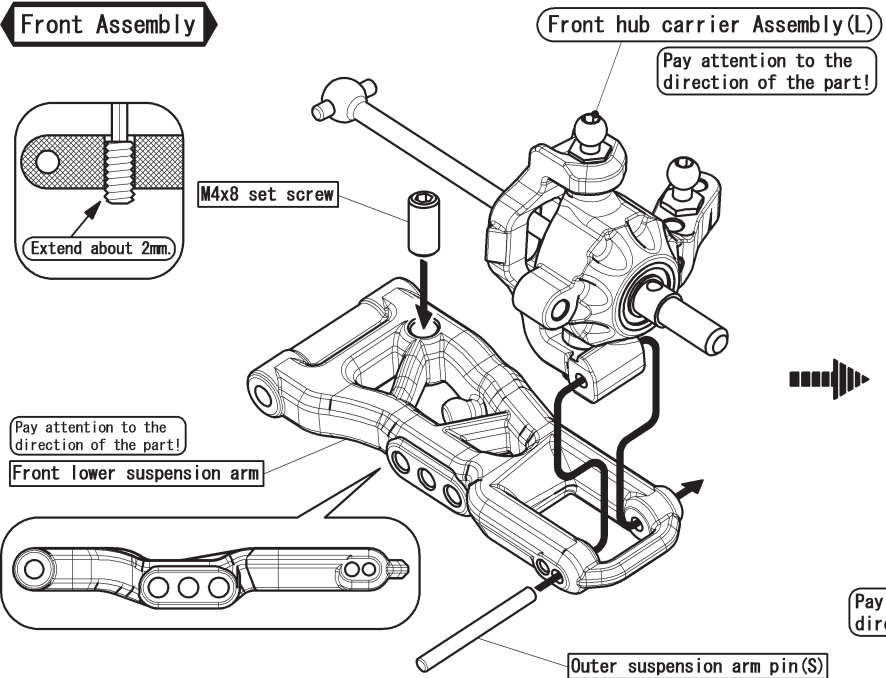

[Assemble each side in the same manner.]

Rear Assembly

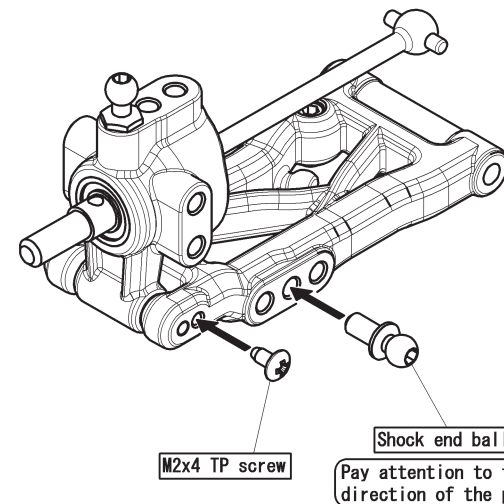
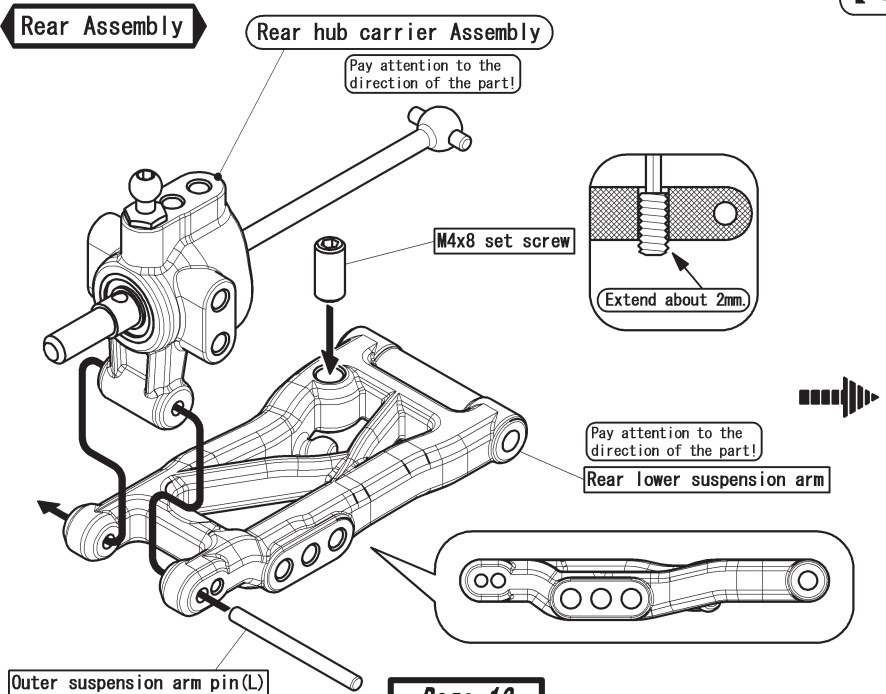

Front Assembly

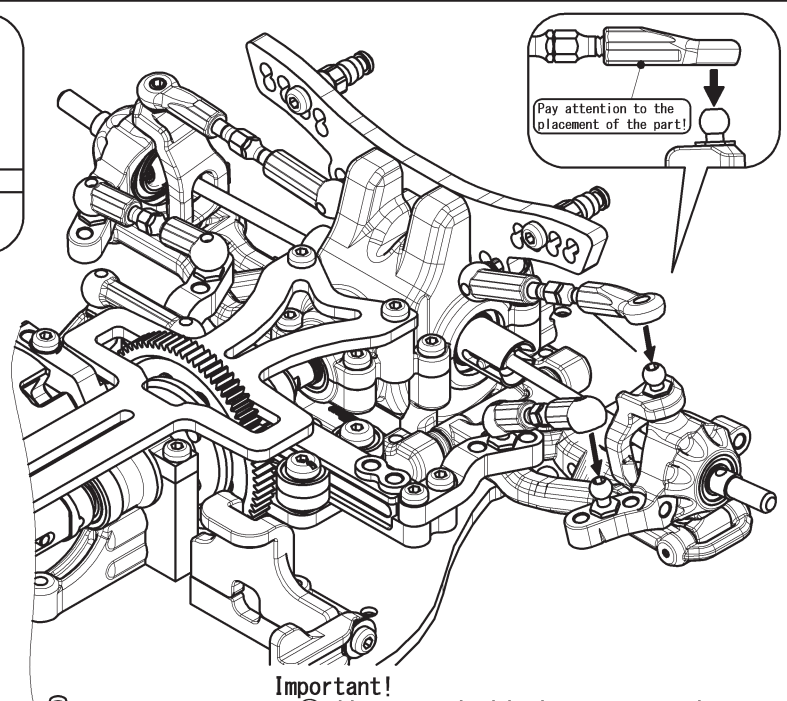
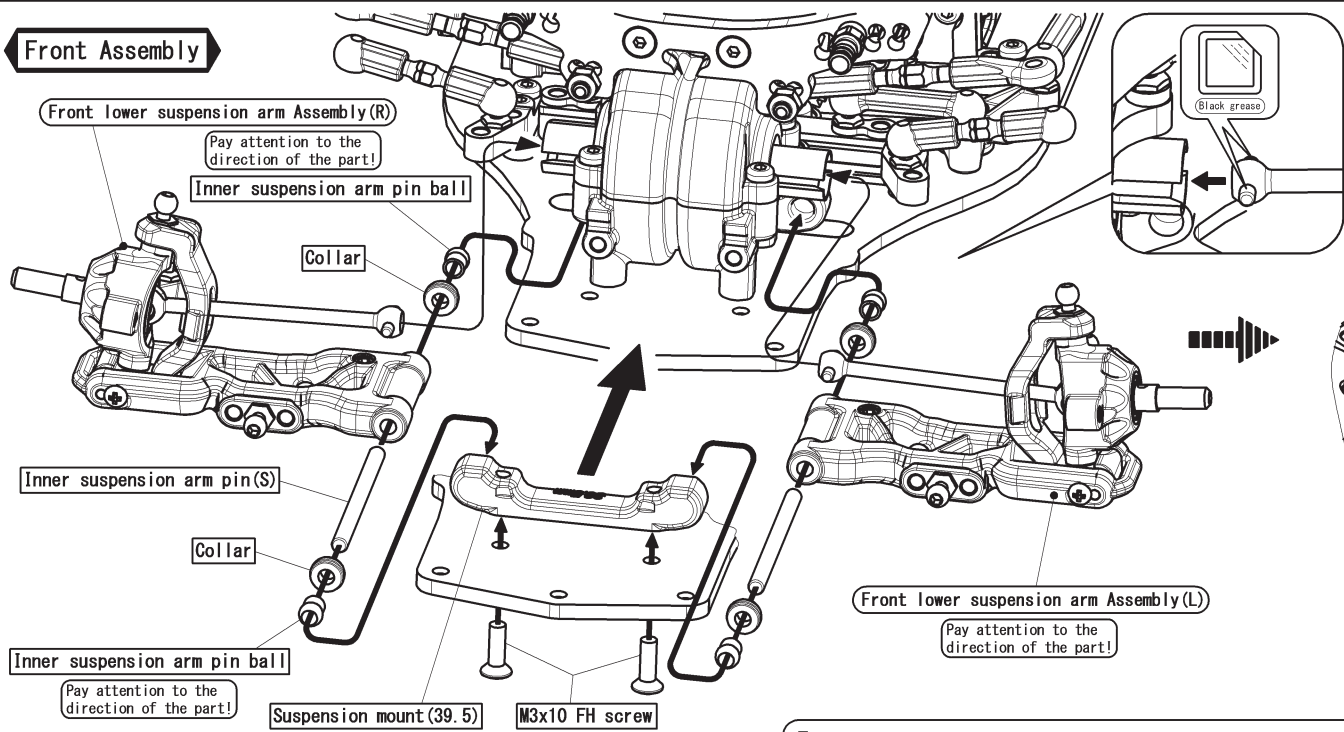

- Important!**
- ① Always apply black grease to the universal driveshaft pins.
 - ② The lower suspension arms assembled in the previous step are different left and right. Follow the diagram closely during assembly.

[Assemble each side in the same manner.]

Rear Assembly

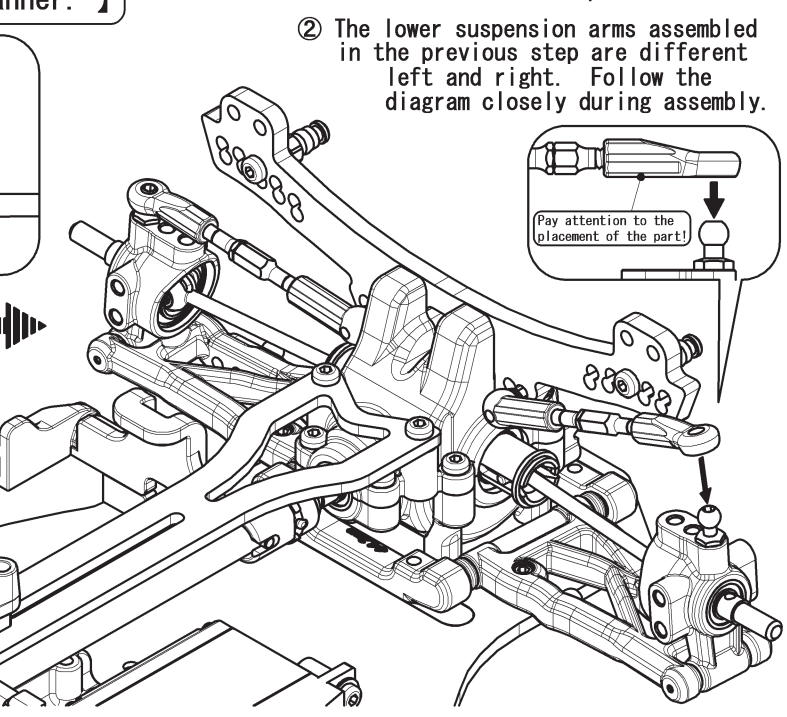
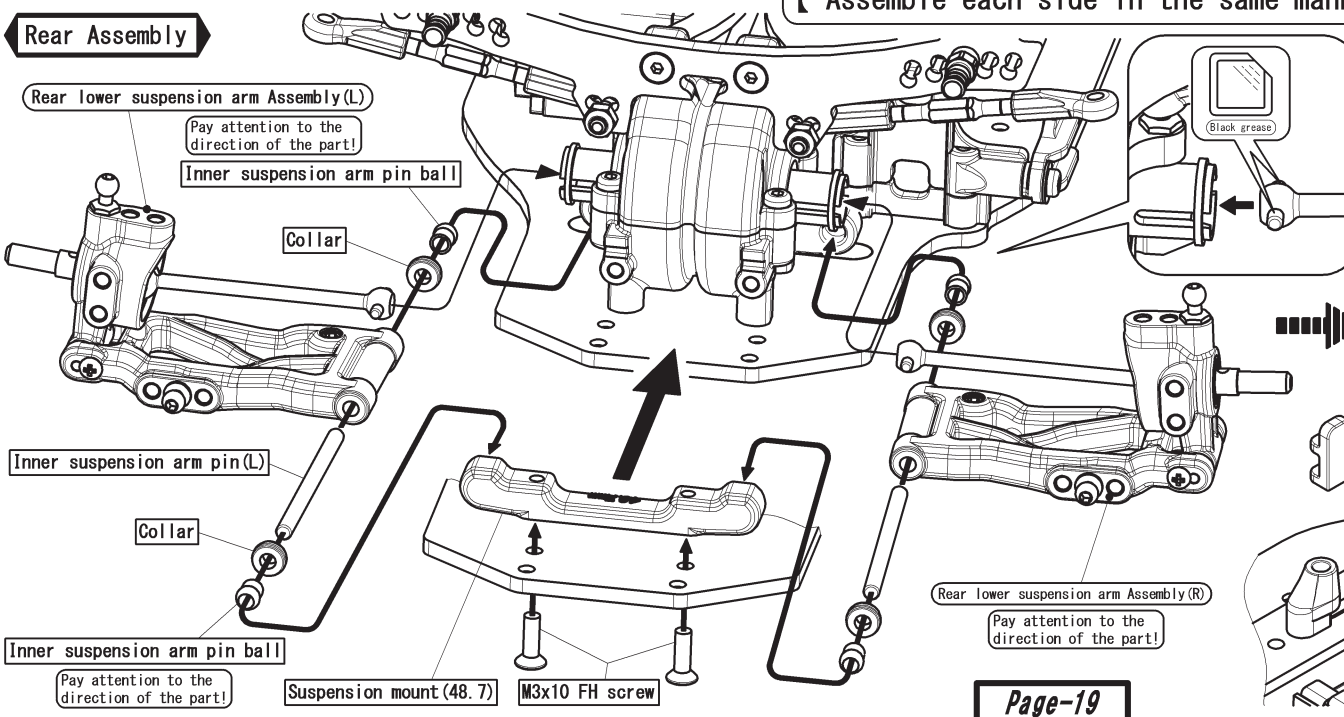

[Bag-12 Contents]

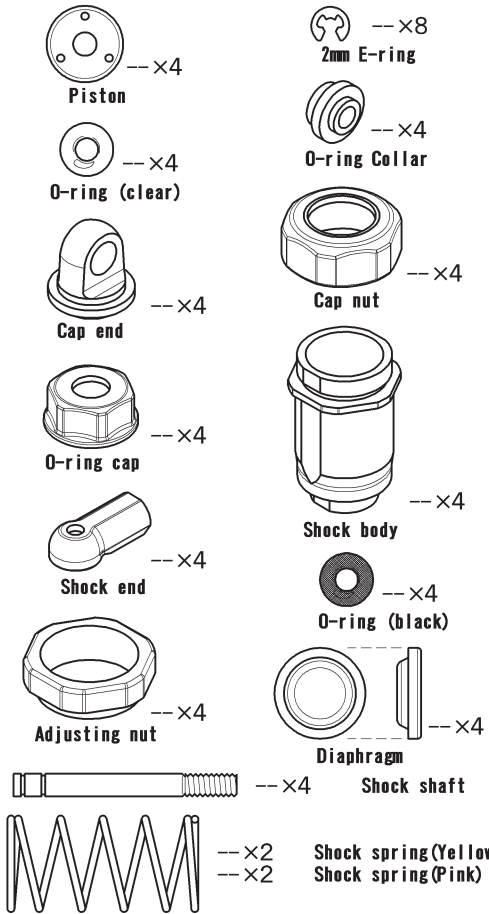

Remaining parts from [Bag-1 Contents]

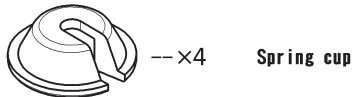

[Bag-15 Contents]

#350 shock oil x 1
#450 shock oil x 1

Shock oil and spring combination Assemble 4 shocks

Front—#450 shock oil & Shock spring (Yellow)
Rear—#350 shock oil & Shock spring (Pink)

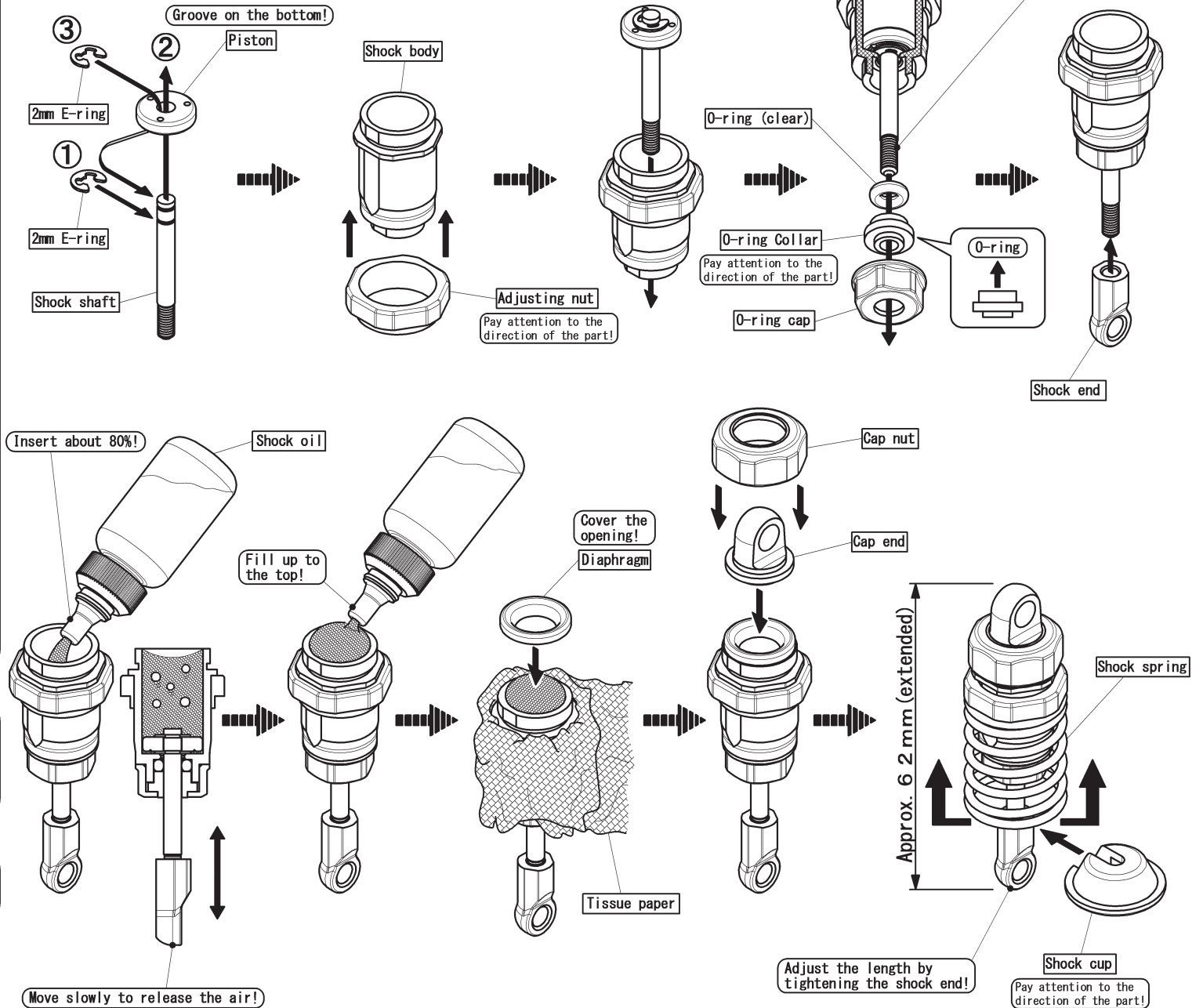

Front Assembly (Yellow)

O-ring (black)

O-ring (black) is attached.

O-ring (black)

Shock Assembly (Yellow)

Rear Assembly (Pink)

O-ring (black)



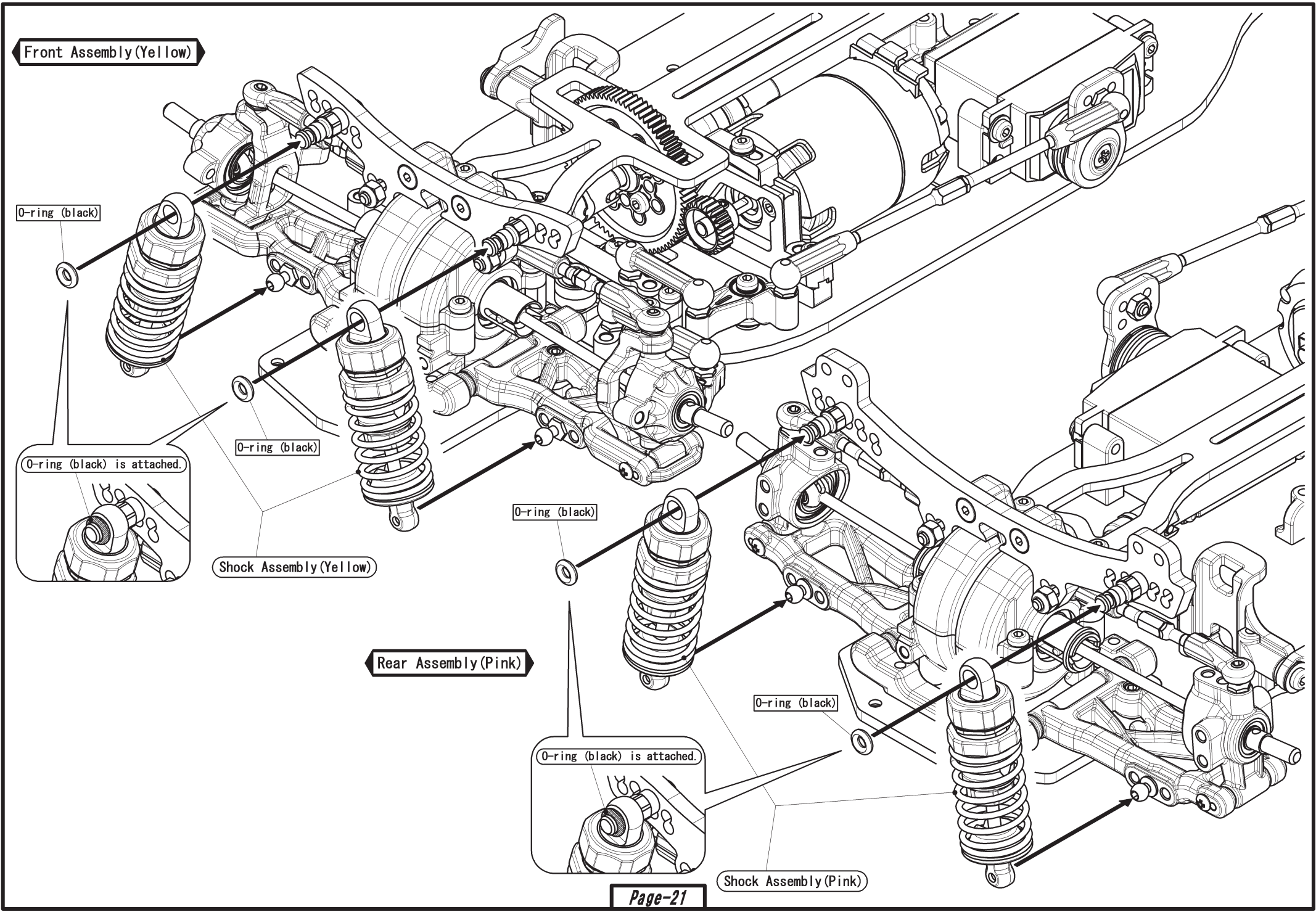

O-ring (black)

O-ring (black) is attached.

Shock Assembly (Pink)

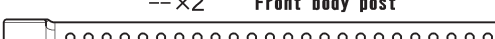

[Bag-13 Contents]

-  --x2 3x10mm flat head screw
-  --x7 3x12mm flat head screw
-  --x4 3x12mm button head screw
-  --x8 Body clips
-  --x2 Front body post
-  --x2 Rear body post

Remaining parts from [Bag-5 Contents]

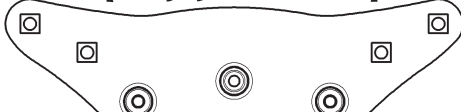
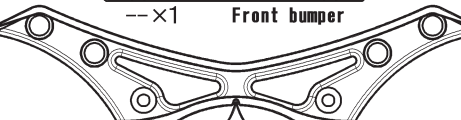
-  --x1 Front bumper
-  --x1 Front bumper support

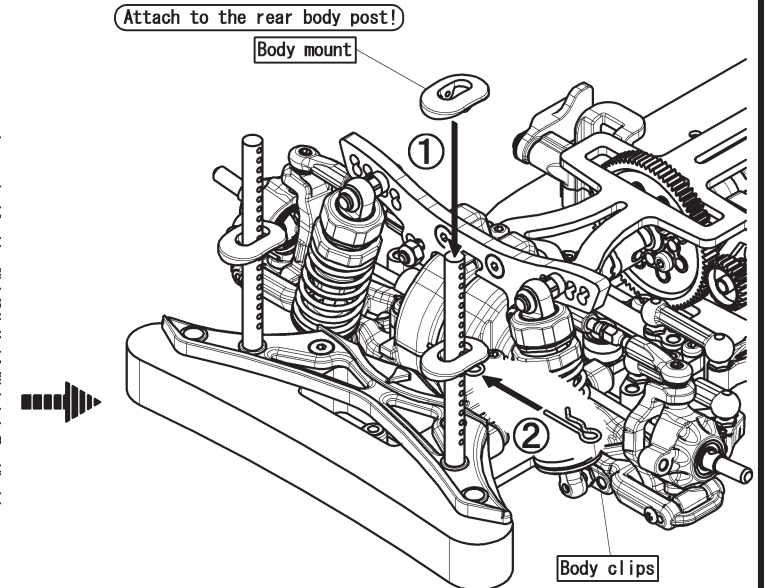
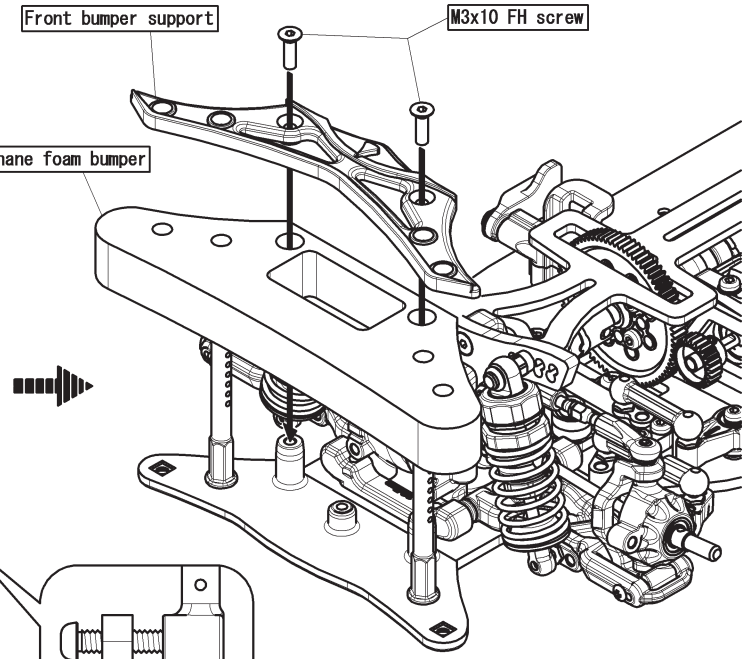
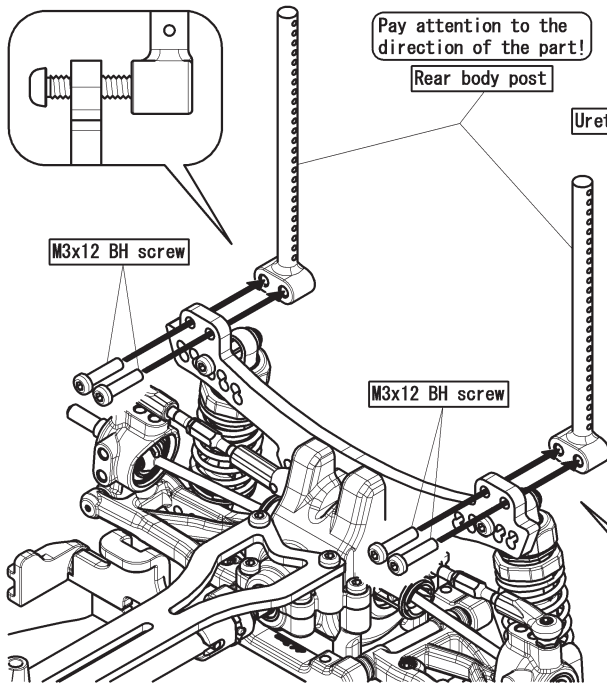
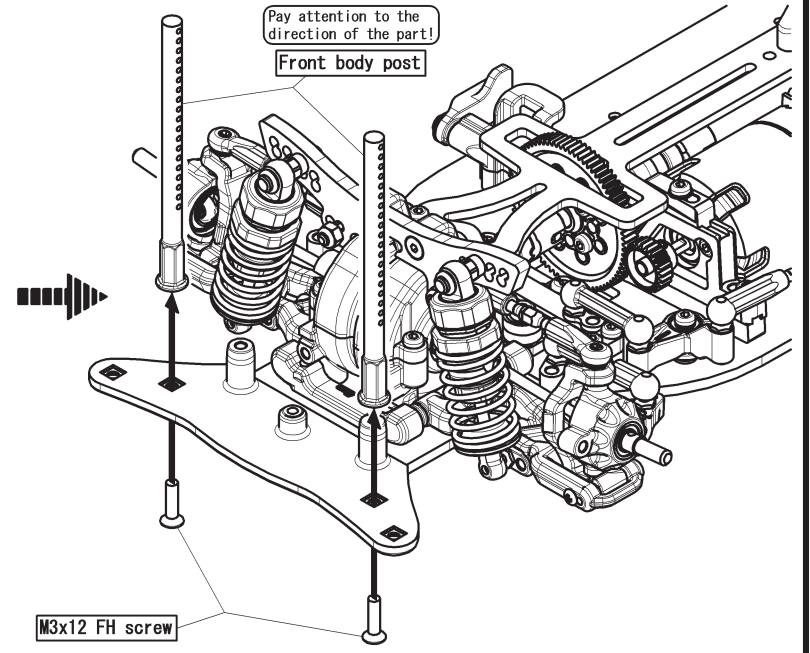
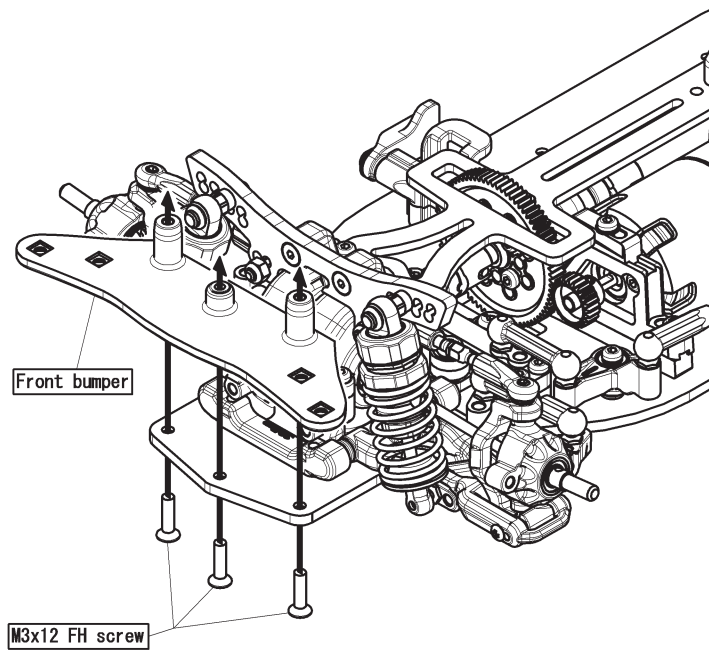

Slide the body mounts onto the body posts to the desired position. Line up the hole on the body mount and body post, and insert a body clip to secure. (Repeat for all body posts.)

Important! ① Adjust the position of the body mount according to the body used.

**Remaining parts from
[Bag-13 Contents]**

---x4 M2x5 tapping screw

Also included: double-sided tape, nylon band, diffuser (Large) & (Small)

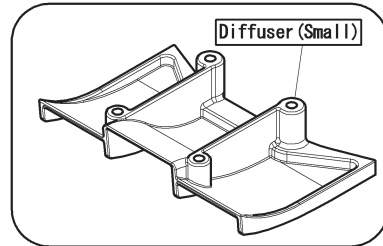

Diffuser-side can't be installed.

Diffuser side(L)

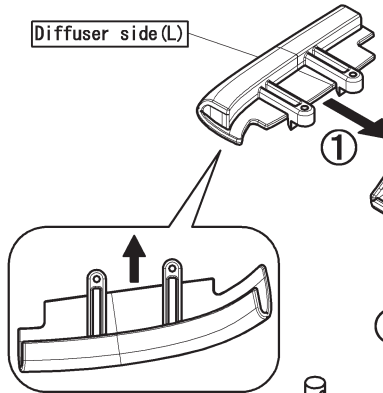

②

M2x5 TP screw

Diffuser (Large)

Diffuser side(R)

②

M2x5 TP screw

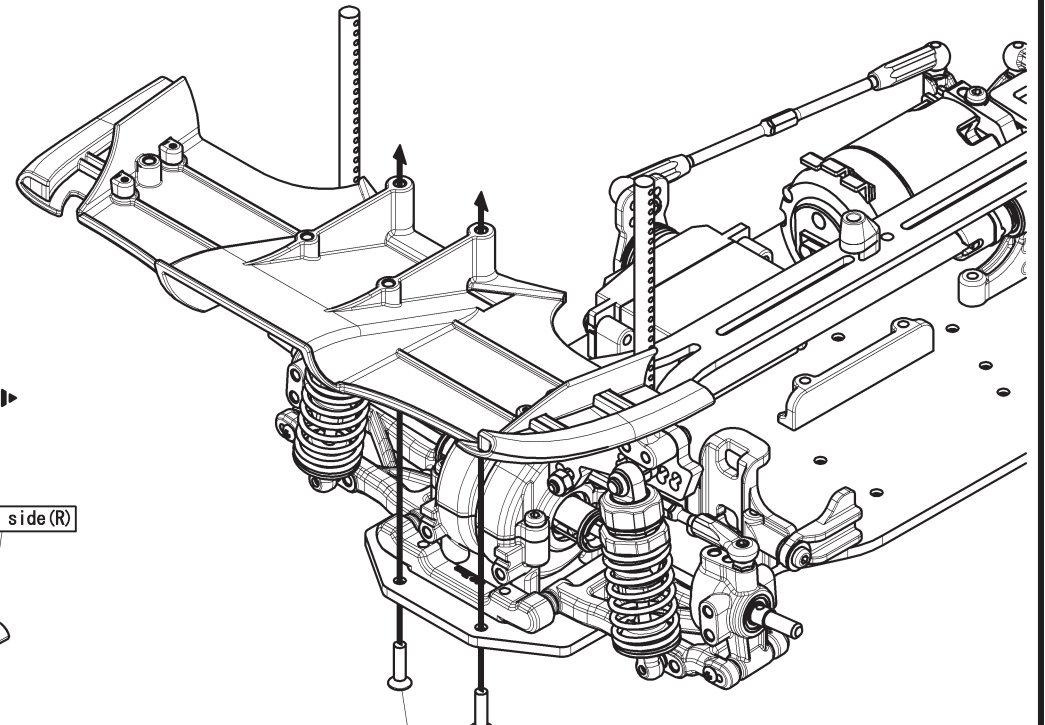
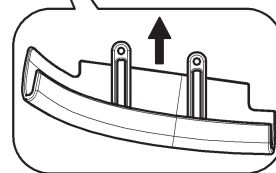

M3x12 FH screw

Antenna tube

Please cut the case where a tube is long.

Sold separately.
Receiver and speed controller

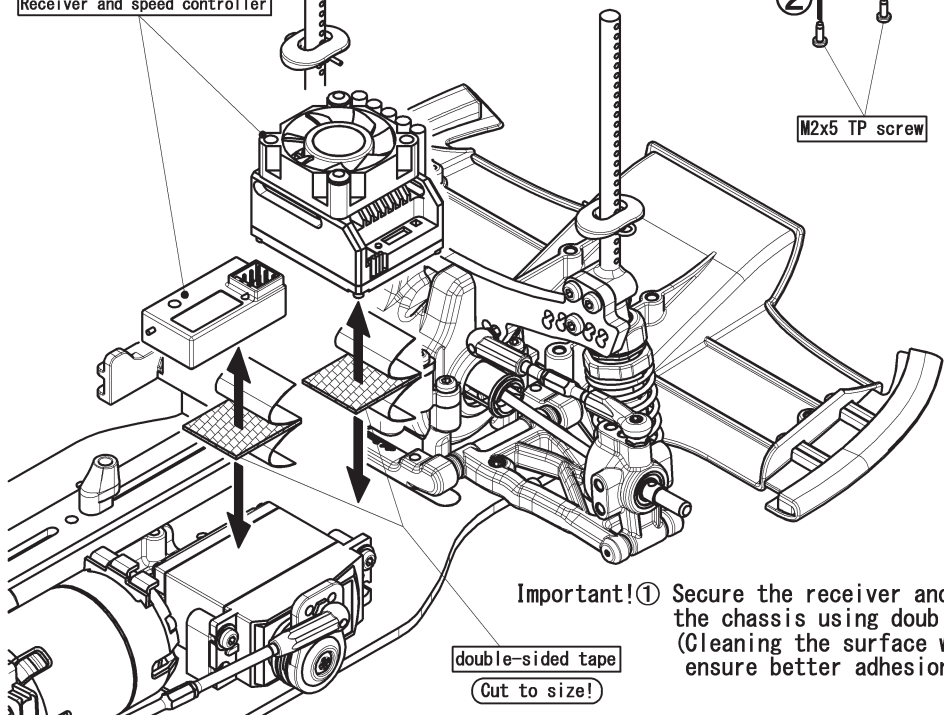

double-sided tape
(Cut to size!)

Slide the antenna wire through the bottom of the antenna mount and insert into the antenna tube. Leave about 1cm of wire at the top of the tube. Insert the antenna tube into the antenna mount.

Important!② Make sure to bundle any remaining antenna wire so that it does not interfere with the drivetrain.

Important!① Secure the receiver and speed controller to the chassis using double-sided tape. (Cleaning the surface with motor spray will ensure better adhesion.)

Drift tire Assembly

Assemble 4 tires

Important!—Wheels and tires not included in kit. Please purchase separately.
Tire of illustration is using [ZR-DR04 ZERO ONE R2 TIRE].

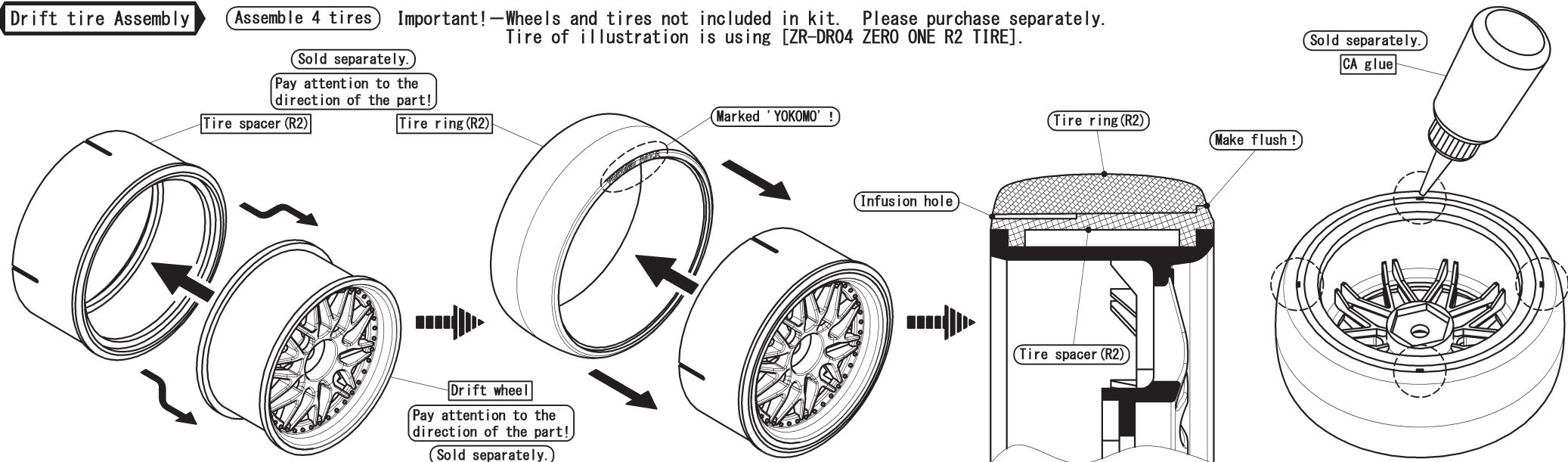

Install the tire spacer onto the wheel.
(It will be difficult to install the ring if the tire is not fully seated onto the wheel.)

Applying a thin amount of oil on the tire spacer will make it easier to install the tire ring.
(Be careful not to apply too much oil.)

Once the sidewalls are flush, insert glue through the four openings located on the inner side.
(If oil was used when installing the tire rings, wait at least 30 minutes before applying the glue.)

[Bag-14 Contents]

- ×4 4mm nylon locknut
- ×4 Wheel hub pin

Remaining parts from [Bag-1 Contents]

- ×4 Wheel hub

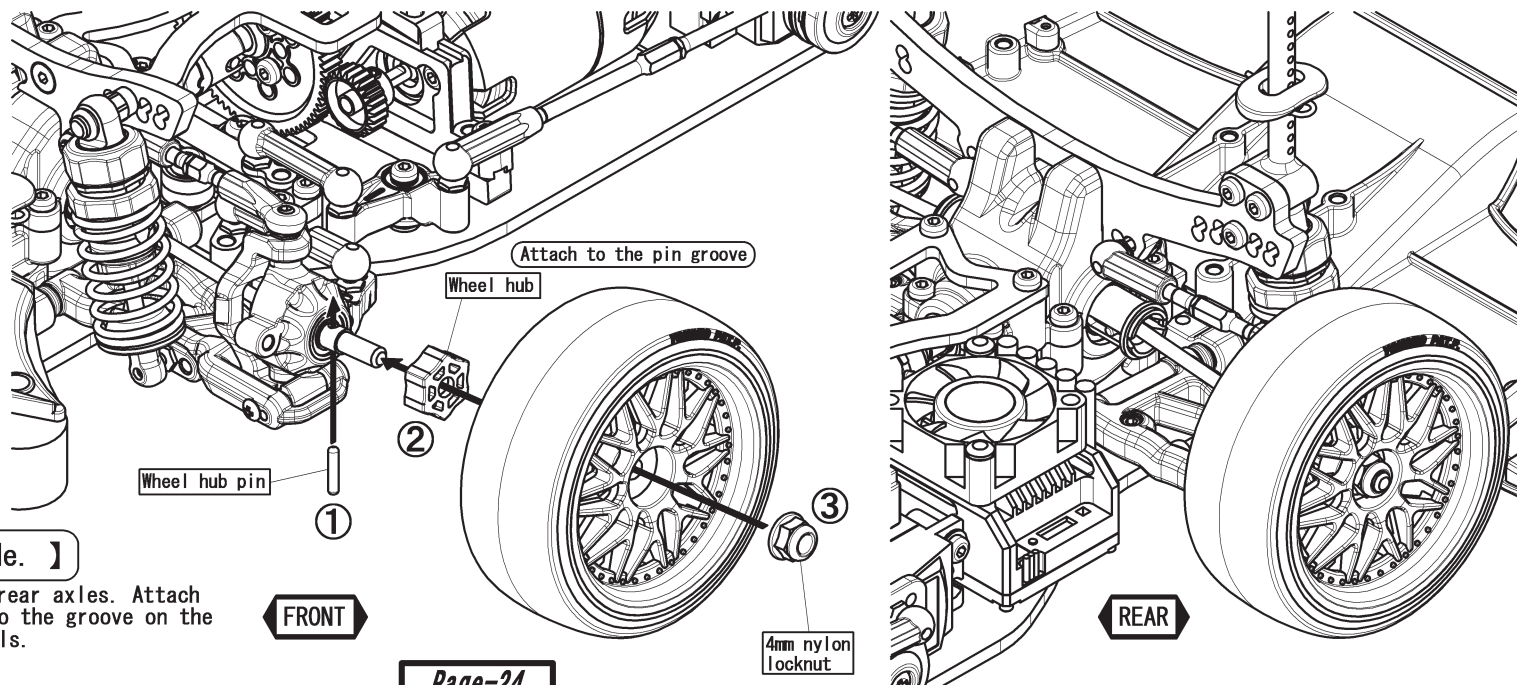

[Repeat for the opposite side.]

Insert the wheel hub pin into both the front and rear axles. Attach the wheel hub onto the axles so that pin fits into the groove on the hub. Use the M4 nylon locknuts to secure the wheels.

Battery Installation

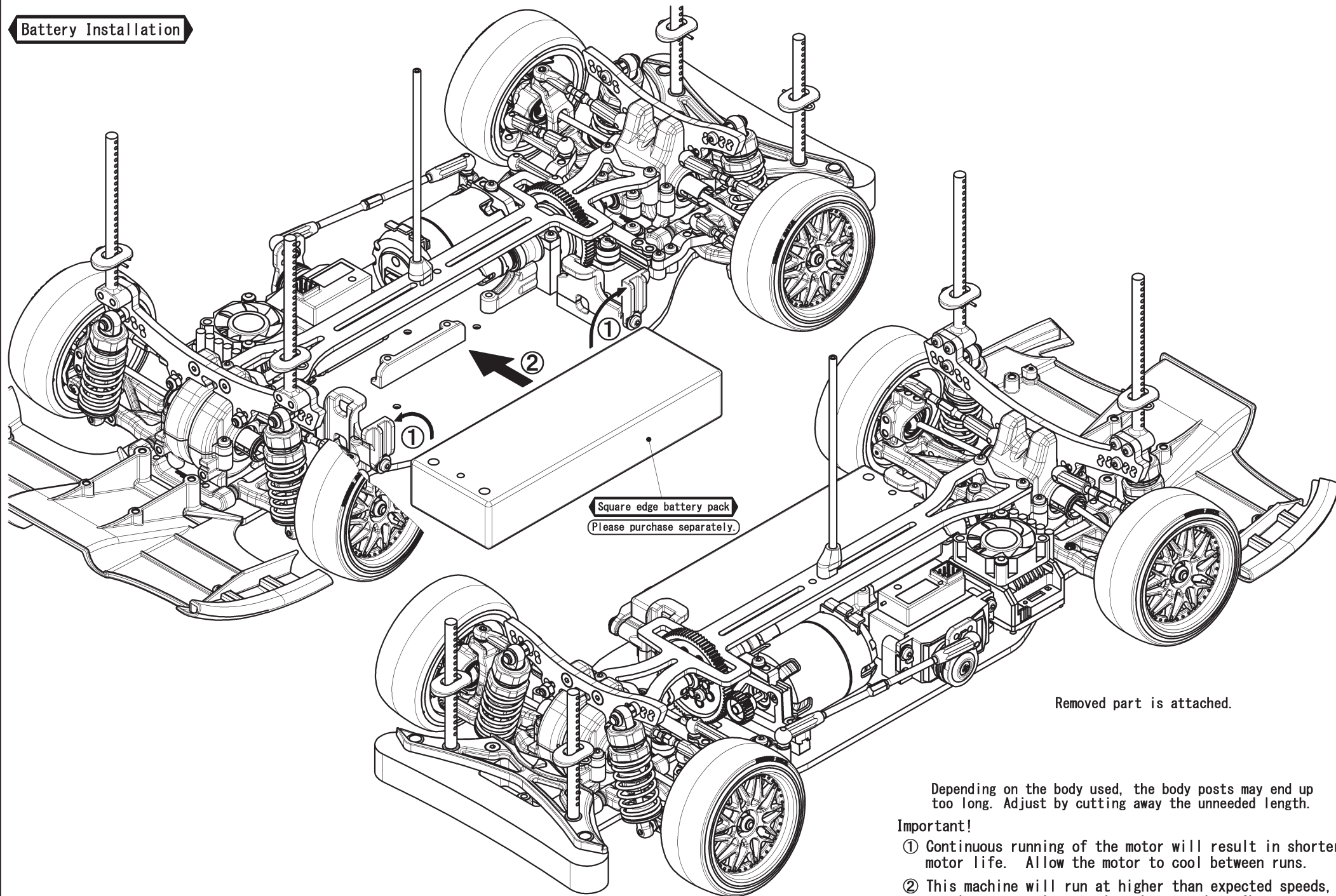

Square edge battery pack
Please purchase separately.

Removed part is attached.

Depending on the body used, the body posts may end up too long. Adjust by cutting away the unneeded length.

Important!

- ① Continuous running of the motor will result in shorter motor life. Allow the motor to cool between runs.
- ② This machine will run at higher than expected speeds, so please exercise caution when running. Choose open, safe areas to run. Enjoy!

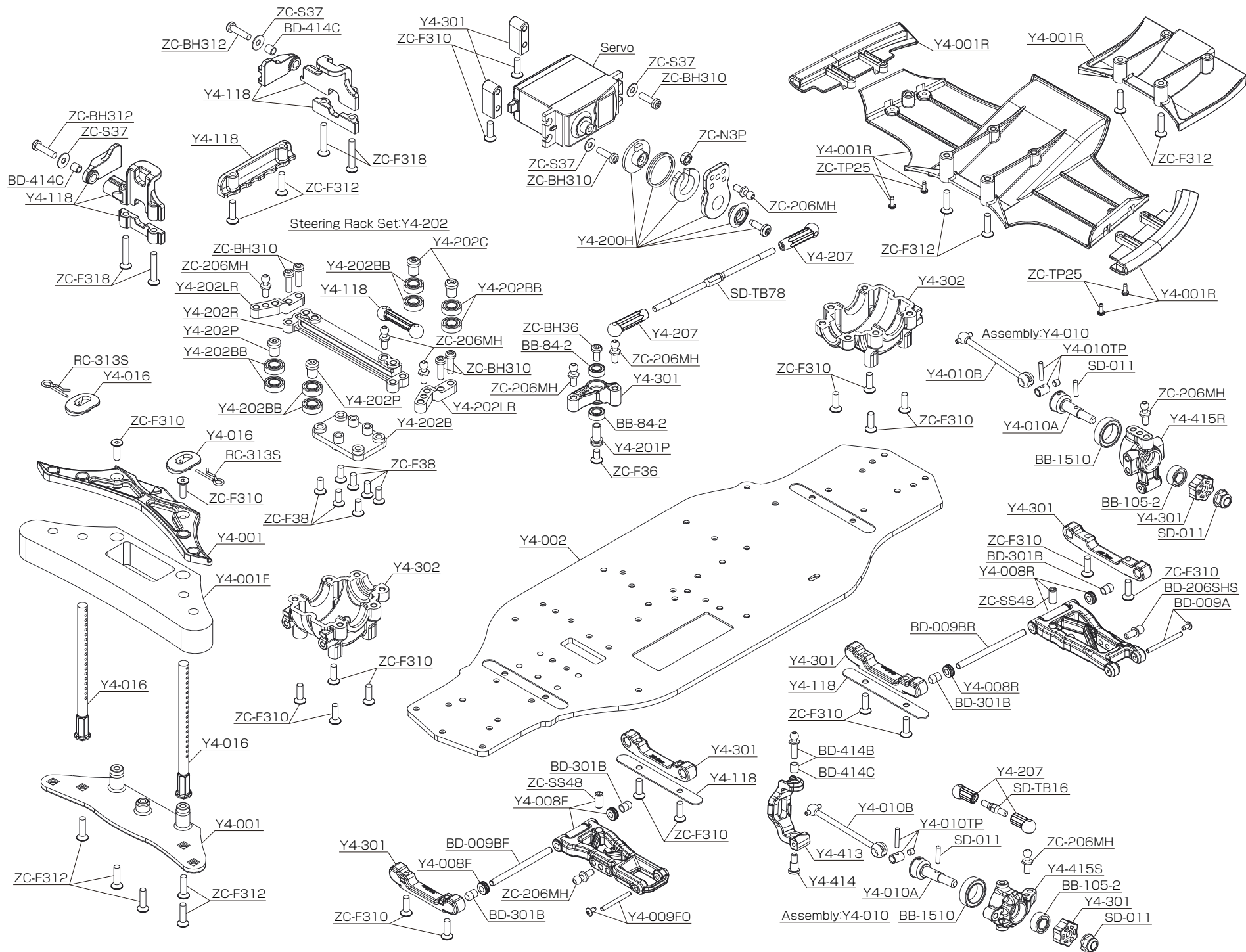

YOKO

SETTING SHEET

Driver	日付 / Date	/	/
コース / Circuit	環境 / Place	<input type="checkbox"/> インドア / Indoor	<input type="checkbox"/> アウトドア / Outdoor
路面 / Track	路面 / Track	<input type="checkbox"/> アスファルト / Asphalt	<input type="checkbox"/> カーペット / Carpet
		<input type="checkbox"/> コンクリート / Concrete	<input type="checkbox"/> プラスチック / Plastic tile
路面状況 / Track situation	路面状況 / Track situation	<input type="checkbox"/> フラット / Flat	<input type="checkbox"/> バンパー / Bump
グリップ / Traction	グリップ / Traction	<input type="checkbox"/> 高い / High	<input type="checkbox"/> 普通 / Medium
		<input type="checkbox"/> 低い / Low	

FRONT

フロント駆動系 / Front Drive

クワンクエイ / One-way X 1

ソリッドブロック / Solid Block X 0.8

ギヤデフ / Gear Diff. X 0.76

(オイル / Oil # _____) X 0.69

ボールデフ / Ball Diff. X 0.59

FCD

STブロック / ST Block X 1

樹脂製 / Molded X 0.8

アルミ製 / Aluminum X 0.76

樹脂製 / Molded X 0.69

アルミ製 / Aluminum X 0.59

スベーク / Spacer

FR mm

FR mm

サスブロック / Sus Block

FF mm

FR mm

ホイール / Wheel Hubs

mm

C/ブ / C-hub

樹脂製 / Molded

アルミ製 / Aluminum

スライドラック / Slide Rack

mm

mm

REAR

リア駆動系 / Rear Drive

ソリッドブロック / Solid Block X 1

ギヤデフ / Gear Diff. X 1.3

(オイル / Oil # _____) X 1.8

ボールデフ / Ball Diff. X 1.5

X 2.0

FCD

樹脂製 / Molded X 1

アルミ製 / Aluminum X 1.3

樹脂製 / Molded X 1.8

アルミ製 / Aluminum X 1.5

樹脂製 / Molded X 2.0

スベーク / Spacer

RF mm

RR mm

サスブロック / Sus Block

RF mm

RR mm

ホイール / Wheel Hubs

mm

樹脂製 / Molded

アルミ製 / Aluminum

mm

mm

スベーク / Spur Gear

枚 (Pitch / pitch)

ピニオンギア / Pinion Gear

枚 (Pitch / pitch)

ボディ / Body

ウイング / Wing

送信機 / Transmitter

サーボ / Servo

モーター / Motor

バッテリー / Battery

ショートバッテリー搭載位置 / Short Battery Position

ディフューザー / Diffuser

ESC

ESC

フロント / Front

リア / Rear

大 / Large

小 / Small

無 / Non

ESC

車高 / Ride Height	車高 / Ride Height
キャンバー / Camber Angle	キャンバー / Camber Angle
スタビ / Sway Bar	スタビ / Sway Bar
1.1 1.2 1.3 1.4	1.1 1.2 1.3 1.4
トルーク / Droop	トルーク / Droop
サスアーム外下 / Arm	サスアーム外下 / Arm
mm	mm
トー角 / Toe Angle	トー角 / Toe Angle
mm	mm
メモ / Notes	メモ / Notes

車高 / Ride Height	車高 / Ride Height
キャンバー / Camber Angle	キャンバー / Camber Angle
スタビ / Sway Bar	スタビ / Sway Bar
1.1 1.2 1.3 1.4	1.1 1.2 1.3 1.4
トルーク / Droop	トルーク / Droop
サスアーム外下 / Arm	サスアーム外下 / Arm
mm	mm
トー角 / Toe Angle	トー角 / Toe Angle
mm	mm
メモ / Notes	メモ / Notes

FRONT	REAR
タイヤ / Tire	タイヤ / Tire
ホイール / Wheel	ホイール / Wheel
オフセット / Offset	オフセット / Offset
コメント / Comment	コメント / Comment

■一次減速比／Primary Gear Ratio

スパーギヤ／Spur Gear T	÷	ピニオンギヤ／Pinion Gear T	=	(A)
----------------------	---	-------------------------	---	-----

■フロント駆動系／Front Drive Train

★ギヤ比／Gear Ratio

リングギヤ／Ring Gear T	÷	ドライブギヤ／Drive Gear T	=	(B)
----------------------	---	------------------------	---	-----

★最終減速比／Final Reduction Ratio

(A)	×	(B)	=	
-----	---	-----	---	--

■リア駆動系／Rear Drive Train

★ギヤ比／Gear Ratio

リングギヤ／Ring Gear T	÷	ドライブギヤ／Drive Gear T	=	(C)
----------------------	---	------------------------	---	-----

★最終減速比／Final Reduction Ratio

(A)	×	(C)	=	
-----	---	-----	---	--

■リアタイヤ回転倍率／Rear Over Drive Ratio

(B)	÷	(C)	=	倍／times
-----	---	-----	---	---------

※リアタイヤがフロントタイヤの ___ 倍回転する／Rear tire rotation is ___ times of the Front one.

■参考資料1：ギヤ歯数／Gears

	Ring G.	Drive G.
標準／Standard	40T	17T
Front x0.88	40T	15T
Front x0.76	40T	13T
Front x0.69	41T	12T
Front x0.59	40T	10T
Rear x1.3	31T	17T
Rear x1.5	27T	17T
Rear x1.8	22T	17T
Rear x2.0	20T	17T

■参考資料2：回転倍率表／Rear over drive ratio

	Front				
	x1.0	x0.88	x0.76	x0.69	x0.59
	x1.0	1.00	1.13	1.31	1.45
	x1.3	1.29	1.46	1.69	1.87
	x1.5	1.48	1.68	1.94	2.15
	x1.8	1.82	2.06	2.38	3.09
	x2.0	2.00	2.27	2.62	3.40
	Rear				
	x1.0	x0.88	x0.76	x0.69	x0.59
	x1.0	1.00	1.13	1.31	1.45
	x1.3	1.29	1.46	1.69	1.87
	x1.5	1.48	1.68	1.94	2.15
	x1.8	1.82	2.06	2.38	3.09
	x2.0	2.00	2.27	2.62	3.40

※リアタイヤがフロントタイヤの ___ 倍回転する。

*Rear tire rotation is ___ times of the Front one.

<YD-4 GEAR RATIO (48 pitch)>

2nd RATIO		SPUR GEAR																																			
2.353		51	52	53	54	55	56	57	58	59	60	61	62	63	64	65	66	67	68	69	70	71	72	73	74	75	76	77	78	79	80	81	82	83	84	85	86
PINION GEAR	17	7.059	7.197	7.336	7.474	7.612	7.751	7.889	8.028	8.166	8.304	8.443	8.581	8.720	8.858	8.997	9.135	9.273	9.412	9.550	9.689	9.827	9.965	10.104	10.242	10.381	10.519	10.657	10.796	10.934	11.073	11.211	11.349	11.488	11.626	11.765	11.903
	18	6.667	6.797	6.928	7.059	7.190	7.320	7.451	7.582	7.712	7.843	7.974	8.105	8.235	8.366	8.497	8.627	8.758	8.889	9.020	9.150	9.281	9.412	9.542	9.673	9.804	9.935	10.065	10.196	10.327	10.458	10.588	10.719	10.850	10.980	11.111	11.242
	19	6.316	6.440	6.563	6.687	6.811	6.935	7.059	7.183	7.307	7.430	7.554	7.678	7.802	7.926	8.050	8.173	8.297	8.421	8.545	8.669	8.793	8.916	9.040	9.164	9.288	9.412	9.536	9.659	9.783	9.907	10.031	10.155	10.279	10.402	10.526	10.650
	20	6.000	6.118	6.235	6.353	6.471	6.588	6.706	6.824	6.941	7.059	7.176	7.294	7.412	7.529	7.647	7.765	7.882	8.000	8.118	8.235	8.353	8.471	8.588	8.706	8.824	8.941	9.059	9.176	9.294	9.412	9.529	9.647	9.765	9.882	10.000	10.118
	21	5.714	5.826	5.938	6.050	6.162	6.275	6.387	6.499	6.611	6.723	6.835	6.947	7.059	7.171	7.283	7.395	7.507	7.619	7.731	7.843	7.955	8.067	8.179	8.291	8.403	8.515	8.627	8.739	8.852	8.964	9.076	9.188	9.300	9.412	9.524	9.636
	22	5.455	5.561	5.668	5.775	5.882	5.989	6.096	6.203	6.310	6.417	6.524	6.631	6.738	6.845	6.952	7.059	7.166	7.273	7.380	7.487	7.594	7.701	7.807	7.914	8.021	8.128	8.235	8.342	8.449	8.556	8.663	8.770	8.877	8.984	9.091	9.198
	23	5.217	5.320	5.422	5.524	5.627	5.729	5.831	5.934	6.036	6.138	6.240	6.343	6.445	6.547	6.650	6.752	6.854	6.957	7.059	7.161	7.263	7.366	7.468	7.570	7.673	7.775	7.877	7.980	8.082	8.184	8.286	8.389	8.491	8.593	8.696	8.798
	24	5.000	5.098	5.196	5.294	5.392	5.490	5.588	5.686	5.784	5.882	5.980	6.078	6.176	6.275	6.373	6.471	6.569	6.667	6.765	6.863	6.961	7.059	7.157	7.255	7.353	7.451	7.549	7.647	7.745	7.843	7.941	8.039	8.137	8.235	8.333	8.431
	25	4.800	4.894	4.988	5.082	5.176	5.271	5.365	5.459	5.553	5.647	5.741	5.835	5.929	6.024	6.118	6.212	6.306	6.400	6.494	6.588	6.682	6.776	6.871	6.965	7.059	7.153	7.247	7.341	7.435	7.529	7.624	7.718	7.812	7.906	8.000	8.094
	26	4.615	4.706	4.796	4.887	4.977	5.068	5.158	5.249	5.339	5.430	5.520	5.611	5.701	5.792	5.882	5.973	6.063	6.154	6.244	6.335	6.425	6.516	6.606	6.697	6.787	6.878	6.968	7.059	7.149	7.240	7.330	7.421	7.511	7.602	7.692	7.783
	27	4.444	4.532	4.619	4.706	4.793	4.880	4.967	5.054	5.142	5.229	5.316	5.403	5.490	5.577	5.664	5.752	5.839	5.926	6.013	6.100	6.187	6.275	6.362	6.449	6.536	6.623	6.710	6.797	6.885	6.972	7.059	7.146	7.233	7.320	7.407	7.495
	28	4.286	4.370	4.454	4.538	4.622	4.706	4.790	4.874	4.958	5.042	5.126	5.210	5.294	5.378	5.462	5.546	5.630	5.714	5.798	5.882	5.966	6.050	6.134	6.218	6.303	6.387	6.471	6.555	6.639	6.723	6.807	6.891	6.975	7.059	7.143	7.227
	29	4.138	4.219	4.300	4.381	4.462	4.544	4.625	4.706	4.787	4.868	4.949	5.030	5.112	5.193	5.274	5.355	5.436	5.517	5.598	5.680	5.761	5.842	5.923	6.004	6.085	6.166	6.247	6.329	6.410	6.491	6.572	6.653	6.734	6.815	6.897	6.978
	30	4.000	4.078	4.157	4.235	4.314	4.392	4.471	4.549	4.627	4.706	4.784	4.863	4.941	5.020	5.098	5.176	5.255	5.333	5.412	5.490	5.569	5.647	5.725	5.804	5.882	5.961	6.039	6.118	6.196	6.275	6.353	6.431	6.510	6.588	6.667	6.745
	31	3.871	3.947	4.023	4.099	4.175	4.250	4.326	4.402	4.478	4.554	4.630	4.706	4.782	4.858	4.934	5.009	5.085	5.161	5.237	5.313	5.389	5.465	5.541	5.617	5.693	5.769	5.844	5.920	5.996	6.072	6.148	6.224	6.300	6.376	6.452	6.528
	32	3.750	3.824	3.897	3.971	4.044	4.118	4.191	4.265	4.338	4.412	4.485	4.559	4.632	4.706	4.779	4.853	4.926	5.000	5.074	5.147	5.221	5.294	5.368	5.441	5.515	5.588	5.662	5.735	5.809	5.882	5.956	6.029	6.103	6.176	6.250	6.324
	33	3.636	3.708	3.779	3.850	3.922	3.993	4.064	4.135	4.207	4.278	4.349	4.421	4.492	4.563	4.635	4.706	4.777	4.848	4.920	4.991	5.062	5.134	5.205	5.276	5.348	5.419	5.490	5.561	5.633	5.704	5.775	5.847	5.918	5.989	6.061	6.132
	34	3.529	3.599	3.668	3.737	3.806	3.875	3.945	4.014	4.083	4.152	4.221	4.291	4.360	4.429	4.498	4.567	4.637	4.706	4.775	4.844	4.913	4.983	5.052	5.121	5.190	5.260	5.329	5.398	5.467	5.536	5.606	5.675	5.744	5.813	5.882	5.952
	35	3.429	3.496	3.563	3.630	3.697	3.765	3.832	3.899	3.966	4.034	4.101	4.168	4.235	4.303	4.370	4.437	4.504	4.571	4.639	4.706	4.773	4.840	4.908	4.975	5.042	5.109	5.176	5.244	5.311	5.378	5.445	5.513	5.580	5.647	5.714	5.782
	36	3.333	3.399	3.464	3.529	3.595	3.660	3.725	3.791	3.856	3.922	3.987	4.052	4.118	4.183	4.248	4.314	4.379	4.444	4.510	4.575	4.641	4.706	4.771	4.837	4.902	4.967	5.033	5.098	5.163	5.229	5.294	5.359	5.425	5.490	5.556	5.621
	37	3.243	3.307	3.370	3.434	3.498	3.561	3.625	3.688	3.752	3.816	3.879	3.943	4.006	4.070	4.134	4.197	4.261	4.324	4.388	4.452	4.515	4.579	4.642	4.706	4.769	4.833	4.897	4.960	5.024	5.087	5.151	5.215	5.278	5.342	5.405	5.469
	38	3.158	3.220	3.282	3.344	3.406	3.467	3.529	3.591	3.653	3.715	3.777	3.839	3.901	3.963	4.025	4.087	4.149	4.211	4.272	4.334	4.396	4.458	4.520	4.582	4.644	4.706	4.768	4.830	4.892	4.954	5.015	5.077	5.139	5.201	5.263	5.325
	39	3.077	3.137	3.198	3.258	3.318	3.379	3.439	3.499	3.560	3.620	3.680	3.741	3.801	3.861	3.922	3.982	4.042	4.103	4.163	4.223	4.284	4.344	4.404	4.465	4.525	4.585	4.646	4.706	4.766	4.827	4.887	4.947	5.008	5.068	5.128	5.189
	40	3.000	3.059	3.118	3.176	3.235	3.294	3.353	3.412	3.471	3.529	3.588	3.647	3.706	3.765	3.824	3.882	3.941	4.000	4.059	4.118	4.176	4.235	4.294	4.353	4.412	4.471	4.529	4.588	4.647	4.706	4.765	4.824	4.882	4.941	5.000	5.059
	41	2.927	2.984	3.042	3.099	3.156	3.214	3.271	3.329	3.386	3.443	3.501	3.558	3.615	3.673	3.730	3.788	3.845	3.902	3.960	4.017	4.075	4.132	4.189	4.247	4.304	4.362	4.419	4.476	4.534	4.591	4.648	4.706	4.763	4.821	4.878	4.935
	42	2.857	2.913	2.969	3.025	3.081	3.137	3.193	3.249	3.305	3.361	3.417	3.473	3.529	3.585	3.641	3.697	3.754	3.810	3.866	3.922	3.978	4.034	4.090	4.146	4.202	4.258	4.314	4.370	4.426	4.482	4.538	4.594	4.650	4.706	4.762	4.818
	43	2.791	2.845	2.900	2.955	3.010	3.064	3.119	3.174	3.228	3.283	3.338	3.393	3.447	3.502	3.557	3.611	3.666	3.721	3.776	3.830	3.885	3.940	3.995	4.049	4.104	4.159	4.213	4.268	4.323	4.378	4.432	4.487	4.542	4.596	4.651	4.706
	44	2.727	2.781	2.834	2.888	2.941	2.995	3.048	3.102	3.155	3.209	3.262	3.316	3.369	3.422	3.476	3.529	3.583	3.636	3.690	3.743	3.797	3.850	3.904	3.957	4.011	4.064	4.118	4.171	4.225	4.278	4.332	4.385	4.439	4.492	4.545	4.599
	45	2.667	2.719	2.771	2.824	2.876	2.928	2.980	3.033	3.085	3.137	3.190	3.242	3.294	3.346	3.399	3.451	3.503	3.556	3.608	3.660	3.712	3.765	3.817	3.869	3.922	3.974	4.026	4.078	4.131	4.183	4.235	4.288	4.340	4.392	4.444	4.497
46	2.609	2.660	2.711	2.762	2.813	2.864	2.916	2.967	3.018	3.069	3.120	3.171	3.222	3.274	3.325	3.376	3.427	3.478	3.529	3.581	3.632	3.683	3.734	3.785	3.836	3.887	3.939	3.990	4.041	4.092	4.143	4.194	4.246	4.297	4.348	4.399	
47	2.553	2.603	2.653	2.703	2.753	2.804	2.854	2.904	2.954	3.004	3.054	3.104	3.154	3.204	3.254	3.304	3.354	3.404	3.454	3.504	3.554	3.605	3.655	3.705	3.755	3.805	3.855	3.905	3.955	4.005	4.055	4.105	4.155	4.205	4.255	4.305	
48	2.500	2.549	2.598	2.647	2.696	2.745	2.794	2.843	2.892	2.941	2.990	3.039	3.088	3.137	3.186	3.235	3.284	3.333	3.382	3.431	3.480	3.529	3.578	3.627	3.676	3.725	3.775	3.824	3.873	3.922	3.971	4.020	4.069	4.118	4.167	4.216	
49	2.449	2.497																																			

<YD-4 GEAR RATIO (64 pitch)>

2nd RATIO		SPUR GEAR																																	
2.353		83	84	85	86	87	88	89	90	91	92	93	94	95	96	97	98	99	100	101	102	103	104	105	106	107	108	109	110	111	112	113	114	115	116
PINION GEAR	23	8.491	8.593	8.696	8.798	8.900	9.003	9.105	9.207	9.309	9.412	9.514	9.616	9.719	9.821	9.923	10.026	10.128	10.230	10.332	10.435	10.537	10.639	10.742	10.844	10.946	11.049	11.151	11.253	11.355	11.458	11.560	11.662	11.765	11.867
	24	8.137	8.235	8.333	8.431	8.529	8.627	8.725	8.824	8.922	9.020	9.118	9.216	9.314	9.412	9.510	9.608	9.706	9.804	9.902	10.000	10.098	10.196	10.294	10.392	10.490	10.588	10.686	10.784	10.882	10.980	11.078	11.176	11.275	11.373
	25	7.812	7.906	8.000	8.094	8.188	8.282	8.376	8.471	8.565	8.659	8.753	8.847	8.941	9.035	9.129	9.224	9.318	9.412	9.506	9.600	9.694	9.788	9.882	9.976	10.071	10.165	10.259	10.353	10.447	10.541	10.635	10.729	10.824	10.918
	26	7.511	7.602	7.692	7.783	7.873	7.964	8.054	8.145	8.235	8.326	8.416	8.507	8.597	8.688	8.778	8.869	8.959	9.050	9.140	9.231	9.321	9.412	9.502	9.593	9.683	9.774	9.864	9.955	10.045	10.136	10.226	10.317	10.407	10.498
	27	7.233	7.320	7.407	7.495	7.582	7.669	7.756	7.843	7.930	8.017	8.105	8.192	8.279	8.366	8.453	8.540	8.627	8.715	8.802	8.889	8.976	9.063	9.150	9.237	9.325	9.412	9.499	9.586	9.673	9.760	9.847	9.935	10.022	10.109
	28	6.975	7.059	7.143	7.227	7.311	7.395	7.479	7.563	7.647	7.731	7.815	7.899	7.983	8.067	8.151	8.235	8.319	8.403	8.487	8.571	8.655	8.739	8.824	8.908	8.992	9.076	9.160	9.244	9.328	9.412	9.496	9.580	9.664	9.748
	29	6.734	6.815	6.897	6.978	7.059	7.140	7.221	7.302	7.383	7.465	7.546	7.627	7.708	7.789	7.870	7.951	8.032	8.114	8.195	8.276	8.357	8.438	8.519	8.600	8.682	8.763	8.844	8.925	9.006	9.087	9.168	9.249	9.331	9.412
	30	6.510	6.588	6.667	6.745	6.824	6.902	6.980	7.059	7.137	7.216	7.294	7.373	7.451	7.529	7.608	7.686	7.765	7.843	7.922	8.000	8.078	8.157	8.235	8.314	8.392	8.471	8.549	8.627	8.706	8.784	8.863	8.941	9.020	9.098
	31	6.300	6.376	6.452	6.528	6.603	6.679	6.755	6.831	6.907	6.983	7.059	7.135	7.211	7.287	7.362	7.438	7.514	7.590	7.666	7.742	7.818	7.894	7.970	8.046	8.121	8.197	8.273	8.349	8.425	8.501	8.577	8.653	8.729	8.805
	32	6.103	6.176	6.250	6.324	6.397	6.471	6.544	6.618	6.691	6.765	6.838	6.912	6.985	7.059	7.132	7.206	7.279	7.353	7.426	7.500	7.574	7.647	7.721	7.794	7.868	7.941	8.015	8.088	8.162	8.235	8.309	8.382	8.456	8.529
	33	5.918	5.989	6.061	6.132	6.203	6.275	6.346	6.417	6.488	6.560	6.631	6.702	6.774	6.845	6.916	6.988	7.059	7.130	7.201	7.273	7.344	7.415	7.487	7.558	7.629	7.701	7.772	7.843	7.914	7.986	8.057	8.128	8.200	8.271
	34	5.744	5.813	5.882	5.952	6.021	6.090	6.159	6.228	6.298	6.367	6.436	6.505	6.574	6.644	6.713	6.782	6.851	6.920	6.990	7.059	7.128	7.197	7.266	7.336	7.405	7.474	7.543	7.612	7.682	7.751	7.820	7.889	7.958	8.028
	35	5.580	5.647	5.714	5.782	5.849	5.916	5.983	6.050	6.118	6.185	6.252	6.319	6.387	6.454	6.521	6.588	6.655	6.723	6.790	6.857	6.924	6.992	7.059	7.126	7.193	7.261	7.328	7.395	7.462	7.529	7.597	7.664	7.731	7.798
	36	5.425	5.490	5.556	5.621	5.686	5.752	5.817	5.882	5.948	6.013	6.078	6.144	6.209	6.275	6.340	6.405	6.471	6.536	6.601	6.667	6.732	6.797	6.863	6.928	6.993	7.059	7.124	7.190	7.255	7.320	7.386	7.451	7.516	7.582
	37	5.278	5.342	5.405	5.469	5.533	5.596	5.660	5.723	5.787	5.851	5.914	5.978	6.041	6.105	6.169	6.232	6.296	6.359	6.423	6.486	6.550	6.614	6.677	6.741	6.804	6.868	6.932	6.995	7.059	7.122	7.186	7.250	7.313	7.377
	38	5.139	5.201	5.263	5.325	5.387	5.449	5.511	5.573	5.635	5.697	5.759	5.820	5.882	5.944	6.006	6.068	6.130	6.192	6.254	6.316	6.378	6.440	6.502	6.563	6.625	6.687	6.749	6.811	6.873	6.935	6.997	7.059	7.121	7.183
	39	5.008	5.068	5.128	5.189	5.249	5.309	5.370	5.430	5.490	5.551	5.611	5.671	5.732	5.792	5.852	5.913	5.973	6.033	6.094	6.154	6.214	6.275	6.335	6.395	6.456	6.516	6.576	6.637	6.697	6.757	6.817	6.878	6.938	6.998
	40	4.882	4.941	5.000	5.059	5.118	5.176	5.235	5.294	5.353	5.412	5.471	5.529	5.588	5.647	5.706	5.765	5.824	5.882	5.941	6.000	6.059	6.118	6.176	6.235	6.294	6.353	6.412	6.471	6.529	6.588	6.647	6.706	6.765	6.824
	41	4.763	4.821	4.878	4.935	4.993	5.050	5.108	5.165	5.222	5.280	5.337	5.395	5.452	5.509	5.567	5.624	5.681	5.739	5.796	5.854	5.911	5.968	6.026	6.083	6.141	6.198	6.255	6.313	6.370	6.428	6.485	6.542	6.600	6.657
	42	4.650	4.706	4.762	4.818	4.874	4.930	4.986	5.042	5.098	5.154	5.210	5.266	5.322	5.378	5.434	5.490	5.546	5.602	5.658	5.714	5.770	5.826	5.882	5.938	5.994	6.050	6.106	6.162	6.218	6.275	6.331	6.387	6.443	6.499
	43	4.542	4.596	4.651	4.706	4.761	4.815	4.870	4.925	4.979	5.034	5.089	5.144	5.198	5.253	5.308	5.363	5.417	5.472	5.527	5.581	5.636	5.691	5.746	5.800	5.855	5.910	5.964	6.019	6.074	6.129	6.183	6.238	6.293	6.347
	44	4.439	4.492	4.545	4.599	4.652	4.706	4.759	4.813	4.866	4.920	4.973	5.027	5.080	5.134	5.187	5.241	5.294	5.348	5.401	5.455	5.508	5.561	5.615	5.668	5.722	5.775	5.829	5.882	5.936	5.989	6.043	6.096	6.150	6.203
	45	4.340	4.392	4.444	4.497	4.549	4.601	4.654	4.706	4.758	4.810	4.863	4.915	4.967	5.020	5.072	5.124	5.176	5.229	5.281	5.333	5.386	5.438	5.490	5.542	5.595	5.647	5.699	5.752	5.804	5.856	5.908	5.961	6.013	6.065
	46	4.246	4.297	4.348	4.399	4.450	4.501	4.552	4.604	4.655	4.706	4.757	4.808	4.859	4.910	4.962	5.013	5.064	5.115	5.166	5.217	5.269	5.320	5.371	5.422	5.473	5.524	5.575	5.627	5.678	5.729	5.780	5.831	5.882	5.934
	47	4.155	4.205	4.255	4.305	4.355	4.406	4.456	4.506	4.556	4.606	4.656	4.706	4.756	4.806	4.856	4.906	4.956	5.006	5.056	5.106	5.156	5.207	5.257	5.307	5.357	5.407	5.457	5.507	5.557	5.607	5.657	5.707	5.757	5.807
	48	4.069	4.118	4.167	4.216	4.265	4.314	4.363	4.412	4.461	4.510	4.559	4.608	4.657	4.706	4.755	4.804	4.853	4.902	4.951	5.000	5.049	5.098	5.147	5.196	5.245	5.294	5.343	5.392	5.441	5.490	5.539	5.588	5.637	5.686
	49	3.986	4.034	4.082	4.130	4.178	4.226	4.274	4.322	4.370	4.418	4.466	4.514	4.562	4.610	4.658	4.706	4.754	4.802	4.850	4.898	4.946	4.994	5.042	5.090	5.138	5.186	5.234	5.282	5.330	5.378	5.426	5.474	5.522	5.570
	50	3.906	3.953	4.000	4.047	4.094	4.141	4.188	4.235	4.282	4.329	4.376	4.424	4.471	4.518	4.565	4.612	4.659	4.706	4.753	4.800	4.847	4.894	4.941	4.988	5.035	5.082	5.129	5.176	5.224	5.271	5.318	5.365	5.412	5.459
	51	3.829	3.875	3.922	3.968	4.014	4.060	4.106	4.152	4.198	4.245	4.291	4.337	4.383	4.429	4.475	4.521	4.567	4.614	4.660	4.706	4.752	4.798	4.844	4.890	4.937	4.983	5.029	5.075	5.121	5.167	5.213	5.260	5.306	5.352
	52	3.756	3.801	3.846	3.891	3.937	3.982	4.027	4.072	4.118	4.163	4.208	4.253	4.299	4.344	4.389	4.434	4.480	4.525	4.570	4.615	4.661	4.706	4.751	4.796	4.842	4.887	4.932	4.977	5.023	5.068	5.113	5.158	5.204	5.249

 この色の組合せは使用不可 (もしくは推奨外) です。/The gearing combinations in this color cannot be used (or are not recommended).

AS A MANUFACTURER OF WORLD CHAMPIONSHIP WINNING CARS,
YOKOMO WILL CONTINUE TO PROVIDE THE BEST AVAILABLE TECHNOLOGY TO R/C ENTHUSIASTS ALL OVER THE WORLD.
ENJOY THIS PRODUCT KNOWING THAT YOU ARE DRIVING ONE OF THE BEST HANDLING R/C CARS EVER DESIGNED.

RC MODEL CARS
YOKOMO
www.teamyokomo.com

世界のブランド YOKOMO

ヨコモは競技用 R/C カー（ラジオコントロールカー）の専門メーカーです。その製品は、全日本選手権、全米選手権、ヨーロッパ選手権、そして R/C カーレースの最高峰である世界選手権レースでも優勝。世界の R/C カーマニアに愛用されています。